

Rehab Assistance for Hansen Diseased Patients

A. N. Nithyaa, R. Prem Kumar

(Dept. of Biomedical Engineering, Rajalakshmi Engineering College,
Thandalam, CHENNAI – 602105).

Abstract: Hansen disease is a chronic disease caused by a bacillus, *Mycobacterium leprae*. According to World Health Organization's latest estimate, among 35% of leprosy cases in India, 48,000 are women. The side effects are permanent disability of hands, feet or eyes. Hansen disease can damage the peripheral nerves and nerves in the skin. This damage can lead to loss of sweat and oil gland function which causes dry and cracked skin on the hands and feet, loss of the ability to feel light touch or, with more severe damage, loss of protective sensation, weakness of the eyelids, preventing proper closure of the lid which protects the eye, loss of strength in the hands and feet. Therefore our main objective is to design a glove for Hansen diseased patients. It is a smart glove with an inbuilt sensor network and data acquisition system for storing the information for the Hansen diseased patients. The main purpose of the system is to provide alertness to the Hansen diseased patients with an assistive device that can improve their confidence and daily independence. Therefore this proposal may prove to be a breakthrough in the medical field and a step towards the enhancement of life and safety of human race.

Key Words: Hansen Disease, Leprosy, SMART GLOVE, ASSISTIVE DEVICE

I. Introduction

Hansen disease is also called Leprosy. Hansen disease is caused by the organism *Mycobacterium leprae*. It is defined as a chronic bacterial disease affecting mainly skin and nerves. If untreated, there can be progressive and permanent damage to the skin, nerves, limbs and eyes. It is a major public health problem in most of the developing world and is often found in conditions connected with poverty, overcrowding, poor sanitation and insufficient nutrition. According to current World Health Organization's data, the current global prevalence rate is around 1.4 cases per 10,000 people. Around 5, 00,000 new cases of leprosy are registered each year. India alone has about 5, 00,000 infected people, which represents 63% of the global occurrences.

Leprosy, a chronic infectious disease that, if left untreated, can cause debilitating deformities and slowly progress throughout one's life. It is characterized by peripheral nerve damage, cutaneous lesions and a wide range of clinical manifestations. The major side effects are permanent disability of hands, feet or eyes. Hansen disease can damage the peripheral nerves and nerves in the skin. This damage can lead to loss of sweat and oil gland function which causes dry and cracked skin on the hands and feet, loss of the ability to feel light touch or, with more severe damage, loss of protective sensation, weakness of the eyelids, preventing proper closure of the lid which protects the eye, loss of strength in the hands

and feet. In order to contract the disease, one has to live in close contact with an infected individual for a prolonged amount of time. These physical effects paired with the social stigma of being infected with this dreaded disease, often lead to those affected being afraid to come forward to seek treatment in the early stages of the disease. Hence there arises a need for rehabilitation.

II. A step towards rehabilitation

The basic concepts behind rehabilitation are that the persons affected with Hansen disease should be restored back to normal social life or as near as possible. Rehabilitation means restoration of economic productivity leading to economic independence. In India economic independence outweigh many other considerations. Rehabilitation in the field of Hansen disease requires greater efforts than the rehabilitation in other types of disabled persons because the question of social acceptance does not arise in non-Hansen disease disabled persons. In the case of a orthopedically handicapped or a blind or deaf person their stay with the family is not prejudiced as in the case of Hansen disease patients. This is due to the stigma attached to the disease. Therefore our paper is a step towards restoring their normal live. Being known the virulence of this disease, most of the research is based on its cure. Some of the existing treatments include drug therapy and chemotherapy. Also steps are being taken to eradicate and to a larger extend control its spread. A step towards rehabilitation is yet to catch up its pace. The main objective of this paper is to design a glove for Hansen diseased patients in order to alert them in case of any physical parameter extremity such as pressure or temperature using an inbuilt sensor network and a data acquisition system for storing the information acquired from the sensor for further analysis.



Fig 1. Picture of a person with Hansen disease(Hansen's disease)

III. General Block Diagram

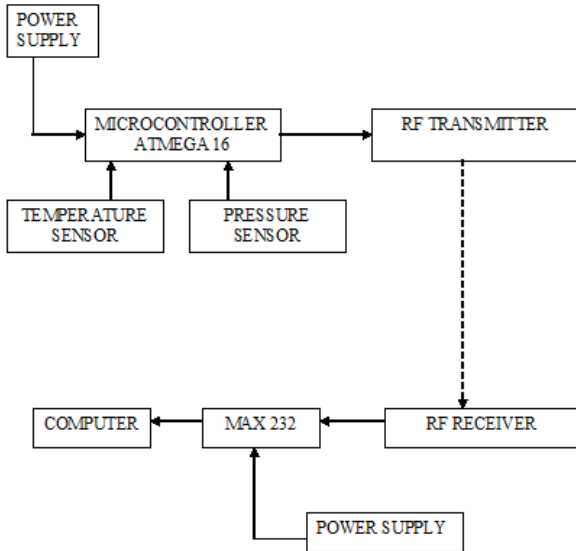

Fig 2. General Block Diagram

3.1 Description of Block Diagram

The block diagram represents the overall working of the glove. In the transmitter part, a temperature and a pressure sensor is used. The temperature sensor used here is LM35 and pressure sensor is FLEXIFORCE. The microcontroller ATMEGA 16 a low-power CMOS 8-bit microcontroller, which acquires the input from the sensors. To drive the microcontroller a power supply is given. These sensors give input to the controller in terms of voltage. The controller is programmed to send the analog voltage to the RF transmitter. At the other end a RF receiver module is placed which obtains the signal from the transmitter. MAX 232 is a level shifter which converts CMOS input levels into RS232 levels. RS-232 (Recommended Standard 232) is a standard for serial binary single-ended data and control signals connecting between a DTE (Data Terminal Equipment) and a DCE (Data Circuit-terminating Equipment). Now the digital values thus obtained is processed in SMART SOFTWARE supported by .NET. It is programmed in such a way that when the temperature and pressure reaches its extremities, indication is shown to the patient through alarm and LED glow respectively.

3.1.1.1 Transmitter Module

Transmitter module has the following components:

- LM35 sensor
- Flexi force sensor
- ATMEGA 16
- Power supply

LM35 sensor

Temperature measurement is very important in all spheres of life. Taking a temperature essentially requires the transmission of a small portion of an object's thermal energy to the sensor, whose function is to convert that energy into an electrical signal. When a contact sensor (probe) is placed inside or on the object, heat conduction takes place through the interface between the object and the probe. Contact temperature sensors measure their own temperature. One infers the temperature of the object to

which the sensor is in contact by assuming or knowing that the two are in thermal equilibrium, that is, there is no heat flow between them. Non Contact Sensors - Most commercial and scientific non contact temperature sensors measure the thermal radiant power of the Infrared or Optical radiation that they receive from a known or calculated area on its surface, or a known or calculated volume within it (in those cases where the object is semitransparent within the measuring wavelength pass band of the sensor). One then infers the temperature of an object from which the radiant power is assumed to be emitted (some may be reflected rather than emitted).

The LM35 series are precision integrated-circuit temperature sensors, whose output voltage is linearly proportional to the Celsius (Centigrade) temperature. The LM35 thus has an advantage over linear temperature sensors calibrated in ° Kelvin, as the user is not required to subtract a large constant voltage from its output to obtain convenient Centigrade scaling. The LM35 does not require any external calibration or trimming to provide typical accuracies of $\pm 1/4^\circ\text{C}$ at room temperature and $\pm 3/4^\circ\text{C}$ over a full -55 to $+150^\circ\text{C}$ temperature range. Low cost is assured by trimming and calibration at the water level. The LM35's low output impedance, linear output, and precise inherent calibration make interfacing to readout or control circuitry especially easy. It can be used with single power supplies, or with plus and minus supplies. As it draws only 60 μA from its supply, it has very low self-heating, less than 0.1°C in still air. The LM35 is rated to operate over a -55° to $+150^\circ\text{C}$ temperature range.

Flexi force Sensor

Pressure is defined as the normal force per unit area exerted by a fluid (liquid or gas) on any surface. It should be noted that pressure is not defined as a vector quantity and is therefore non directional.

Flexi force pressure sensors can measure force between almost any two surfaces and is durable enough to stand up to most environments. Flexi force has better sensor properties, linearity, hysteric, drift and temperature sensitivity than any other thin film force sensor. Its single element sensor acts as a resistor in an electrical circuit. When the sensor is unloaded, its resistance is very high. When a force is applied to the sensor, this resistance decreases. The resistance can be read by connecting an ohm meter to the outer two pins of the sensor connector and applying a force to the sensing area. There are many ways to integrate the sensor into an application. One way is to incorporate it into a force-to-voltage circuit. A means of calibration must be established to convert the output into the appropriate engineering units. Depending on the setup, an adjustment could then be done to increase or decrease the sensitivity of the sensor.

The Flexi Force sensor is an ultra-thin and flexible printed circuit, which can be easily integrated into most applications. With its paper-thin construction, flexibility and force measurement ability, the Flexi Force sensor can measure force between almost any two surfaces and is durable enough to stand up to most environments. Flexi Force has better force sensing properties, linearity, hysteric, drift, and temperature sensitivity than any other thin-film force sensors. The "active sensing area" is a 0.375" diameter circle at the end of the sensor. The sensors are constructed of two layers of substrate. This

substrate is composed of polyester film (or Polyimide in the case of the High-Temperature Sensors). On each layer, a conductive material (silver) is applied, followed by a layer of pressure-sensitive ink. Adhesive is then used to laminate the two layers of substrate together to form the sensor. The silver circle on top of the pressure-sensitive ink defines the “active sensing area.” Silver extends from the sensing area to the connectors at the other end of the sensor, forming the conductive leads. Flexi Force sensors are terminated with a solder able male square pin connector, which allows them to be incorporated into a circuit. The two outer pins of the connector are active and the center pin is inactive. The length of the sensors can be trimmed by Tekscan to predefined lengths of 2”, 4” and 6” or can be trimmed by the customer. If the customer trims the sensor, a new connector must be attached. This can be accomplished by purchasing staked pin connectors and crimping tool. A conductive epoxy can also be used to adhere small wires to each conductor. The sensor acts as a variable resistor in an electrical circuit. When the sensor is unloaded, its resistance is very high (greater than 5 Meg-ohm); when a force is applied to the sensor, the resistance decreases. Connecting an ohmmeter to the outer two pins of the sensor connector and applying a force to the sensing area can read the change in resistance. Sensors should be stored at temperatures in the range of 15°F (-9°C) to 165°F (74°C).



Fig 3. Flexi force Sensor

ATmega16

The ATmega16 is a low-power CMOS 8-bit microcontroller based on the AVR enhanced RISC architecture. By executing powerful instructions in a single clock cycle, the ATmega16 achieves throughputs approaching 1 MIPS per MHz allowing the system designer to optimize power consumption versus processing speed. The ATmega16 provides the following features: 16 Kbytes of In-System Programmable Flash Program memory with Read-While-Write capabilities, 512 bytes EEPROM, 1 Kbytes SRAM, 32 general purpose I/O lines, 32 general purpose working registers, a JTAG interface for Boundary scan, On-chip Debugging support and programming, three flexible Timer/Counters with compare modes, Internal and External Interrupts, a serial programmable USART, a byte oriented Two-wire Serial Interface, an 8-channel, 10-bit ADC with optional differential input stage with programmable gain (TQFP package only), a programmable Watchdog Timer with Internal Oscillator, an SPI serial port, and six software selectable power saving modes. The Idle mode stops the

CPU while allowing the USART, Two-wire interface, A/D Converter, SRAM, Timer/Counters, SPI port, and interrupt system to continue functioning. The Power-down mode saves the register contents but freezes the Oscillator, disabling all other chip functions until the next External Interrupter Hardware Reset. In Power-save mode, the Asynchronous Timer continues to run, allowing the user to maintain a timer base while the rest of the device is sleeping. The ADC Noise Reduction mode stops the CPU and all I/O modules except Asynchronous Timer and ADC, to minimize switching noise during ADC conversions. In Standby mode, the crystal/resonator Oscillator is running while the rest of the device is sleeping. This allows very fast start-up combined with low-power consumption. In Extended Standby mode, both the main Oscillator and the Asynchronous Timer continue to run. The device is manufactured using Atmel’s high density nonvolatile memory technology. The On chip ISP Flash allows the program memory to be reprogrammed in-system through an SPI serial interface, by a conventional nonvolatile memory programmer, or by an On-chip Boot program running on the AVR core. The boot program can use any interface to download the application Program in the Application Flash memory. Software in the Boot Flash section will continue to run while the Application Flash section is updated, providing true Read-While-Write operation. By combining an 8-bit RISC CPU with In-System Self-Programmable Flash on a monolithic chip, the Atmel ATmega16 is a powerful microcontroller that provides a highly-flexible and cost-effective solution to many embedded control applications.

Power Supply

Using the circuit shown in Figure 13, the following voltages at a current limited to one ampere are obtained (3V, 4.5V). The AC main is stepped down by transformer X1 to deliver the secondary output of 18V AC at a maximum current of 1A dependent on the load. The transformer output is rectified by the bridge rectifier comprising diodes D1 through D4, filtered by capacitor C1 and to regulator IC LM317, which is a 3 terminal positive regulator capable of providing 1.2V to 37V at 1.5A current to the load Resistor R3 and R2 are used to produce 3 V at the output, Similarly Resistor R5 and R4 are used to produce 4.5 V at the output.

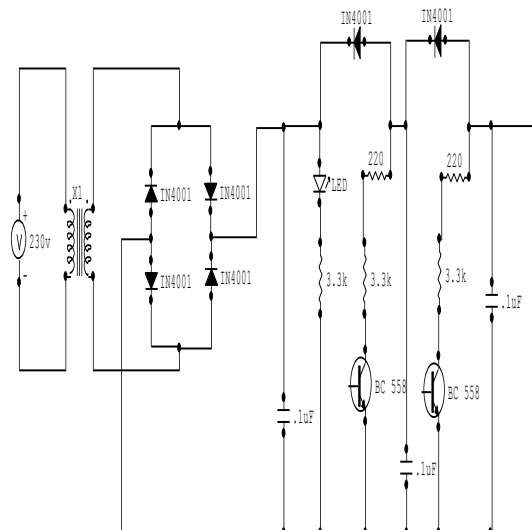

Fig 4. Power Supply

Capacitors. C2 and C3 bypass any ripple in the output. Diodes D5 and D6 are used as the protection diode. Heat sink is used for IC LM 317 to dissipate the heat from it. The LM386 is a power amplifier designed for use in low voltage consumer applications. The gain is internally set to 20 to keep the external part count low, but the addition of an external resistor and capacitor between pins 1 and 8 will increase the gain to any value from 20 to 200. The inputs are ground referenced while the output automatically biases to one-half the supply voltage. The quiescent power drain is only 24 mill watts when operating from a 6-volt supply, making LM386 ideal for battery operation

3.1.1.2 Receiver Module

The receiver module has the following components:

- Level Shifter
- MAX 232
- RF Module

MAX 232

The MAX232 is a dual driver/receiver that includes a capacitive voltage generator. Each receiver has a typical threshold of 1.3 V and a typical hysteresis of 0.5 V, and can accept ± 30 -V inputs. Each driver converts CMOS input levels into RS232 levels.

RF Module

RS-232 (Recommended Standard 232) is a standard for serial binary single-ended data and control signals connecting between a DTE (Data Terminal Equipment) and a DCE (Data Circuit-terminating Equipment). It is commonly used in computer serial ports. The signal levels for RS-232 represent a digital 1 bit as a voltage in the range of 5 to 12 V on the wire, and a digital 0 bit as a voltage of negative 5 to 12 V on the wire. RS-232 is typically implemented in a full duplex fashion, since each station can transmit to the other simultaneously using separate wires. RS-232 can be made to operate at a variety of bit rates, but typically is used at bit rates from 300 bit/s up to 115,200 bit/s.

IV. Conclusions

An Alarm is used and if there is any abnormal condition, it will initiate the buzzer. This alarm will alert the patient. Once the abnormality is rectified, the buzzer is terminated. Light emitting diodes are simply LEDs function in converting the voltage and exhibiting it in the form of light. They are used as indicators. These like alarms, are used to indicate abnormal conditions. They glow when the ideal conditions are disturbed. This is used to indicate pressure abnormality. In our paper the transmitter and receiver module is miniaturized. Also a data acquisition system is used to transfer the data. Thus smart glove is highly reliable and low cost. The main aim of this paper is to assist the Hansen diseased patients in order to alert them in case of any physical extremities.

Acknowledgements

The authors wish to thank the Chairman and Chairperson of Rajalakshmi Engineering College, Chennai for providing all the facilities required for carrying out this work. They also thank the Principal, Rajalakshmi Engineering College, Chennai for his constant encouragement and guidance.

References

1. World Health Organization, Regional Office for South-East Asia. Enhanced Global Strategy for Further Reducing the Disease Burden due to Hansen disease(Plan period: 2011-2015). 2009. http://www.searo.who.int/LinkFiles/GLP_SEA-GLP-2009_3.pdf accessed August 2010.
2. Department of Health and Ageing. National Notifiable Diseases Surveillance System. <http://www9.health.gov.au/cda/Source/CDA-index.cfm> accessed September 2010.
3. Department of Health and Families. Northern Territory Notifiable Diseases System
4. Rees RJW, McDougall AC. Airborne Infection with Mycobacterium Leprae in Mice. J. FMed Microbiol.
5. CARVALHO-SILVA, D. R., SANTOS, F. R., ROCHA, J. and PENA, S. D. The phylogeography of Brazilian Y-chromosome lineages. Am. J. Hum. Genet. 68 (2001) 281–286.
6. RIDLEY, D.S., and JOPLING, W. H. Classification of leprosy according to immunity; a five-group system. Int. J. Lepr. 34 (1966) 255–273.
7. QIN-XUE, W., GAN-YUN, Y., LI-LIN, Z., HUI-WEN, S., QI, L., XIN-YU, L., ZHOU-XIANG, M., and ZHI-WEN, L. Determination of antibodies in dried blood from earlobes of leprosy patients by enzyme linked immunosorbent assay—a preliminary report. Int. J. Lepr. Other Mycobact. Dis. 53 (1985) 565–570.
8. <http://www.nps.gov/kala/>
9. <http://www.leprosyjournal.org/leproline/?request=in dex-html>.
10. <http://www.technologystudent.com/elec1/therm1.htm>
11. <http://www.omega.com/prodinfo/thermistor.html>
12. Rehabilitation of Hansen disease Affected Persons Problems & Challenges for Provision of Services