

Optimal Location of Statcom for Power Flow Control

S. S. Chandrakanth, A. Ramulu

M. Tech (PS&A) GITAM University, Visakhapatnam, India

ABSTRACT: Power flow control in a long transmission line plays a vital role in electrical power system. This paper uses the shunt connected STATCOM for the control of voltage and power flow. The proposed device is used in different locations such as sending end, middle and receiving end of the transmission line. The PWM control is used to generate the firing pulses of the controller circuit. Simulation modeling of the system is carried out using MATLAB/SIMULINK. Based on a voltage-source converter, the STATCOM regulates system voltage by absorbing or generating reactive power. This paper deals with a cascaded multilevel converter model, which is a 48-pulse (three levels) GTO converter. The simulation studies are carried for sending end, middle and receiving end of the transmission line. The objective is to define the reactive power generated and voltage control at different locations (at sending end, middle, receiving end) of transmission line using STATCOM.

KEYWORDS: FACTS device, STATCOM, SVC, PWM, MATLAB /Simulink.

I. INTRODUCTION

The power system is an interconnection of generating units to load centres through high voltage electric transmission lines and in general is mechanically controlled. It can be divided into three subsystems: generation, transmission and distribution subsystems. In order to provide cheaper electricity the deregulation of power system, which will produce separate generation, transmission and distribution companies, is already being performed. At the same time electric power demand continues to grow and also building of the new generating units and transmission circuits is becoming more difficult because of economic and environmental reasons. Therefore, power utilities are forced to rely on utilization of existing generating units and to load existing transmission lines close to their thermal limits. However, stability has to be maintained at all times. Hence, in order to operate power system effectively, without reduction in the system security and quality of supply, even in the case of contingency conditions such as loss of transmission lines and/or generating units, which occur frequently, and will most probably occur at a higher frequency under deregulation, a new control strategies need to be implemented.

The future growth of power systems will rely more on increasing capability of already existing transmission systems, rather than on building new transmission lines and power stations, for economical and environmental reasons. Ideally, these new controllers should be able to control voltage levels and flow of active and reactive power on transmission lines to allow for their secure loading, to full thermal capability in some cases, with no reduction of system stability and security.

The location of STATCOM for power flow control in transmission system has been presented [1]. The FACTS devices are introduced in the power system transmission for the reduction of the transmission line losses and also to increase the transfer capability. STATCOM is VSC based controller to regulate the voltage by varying the reactive power in a long transmission line. The effectiveness of SVC and STATCOM of same rating for the enhancement of power flow has been demonstrated [2]. The modeling of converter-based controllers when two or more VSCs are coupled to a dc link has been presented [3]. The optimal location of shunt FACTS devices in transmission line for highest possible benefit under normal condition and has been investigated [4]. A shunt connected controllable source of reactive power, and two series connected voltage-sourced converters - one on each side of the shunt device was presented [5]. An overview of how series connected and combined series/shunt connected FACTS controllers are studied in an AC system has been highlighted [6]. The optimum required rating of series and shunt flexible ac transmission systems controllers for EHVAC long transmission lines by computing 'optimum compensation requirement' (OCR) for different loading conditions has been demonstrated [7]. A series passive compensation and shunt active compensation provided by a static synchronous compensator (STATCOM) connected at the electrical centre of the transmission line to minimize the effects of SSR has been presented [8]. A novel approach for damping inter-area oscillations in a large power network using multiple STATCOMs was given [9]. The effective utilization of FACTS device called unified power flow controller (UPFC) for power flow control was presented [10].

II. OPERATING PRINCIPLE

A STATCOM consists of a coupling transformer, an inverter and a DC capacitor as shown in fig 1.

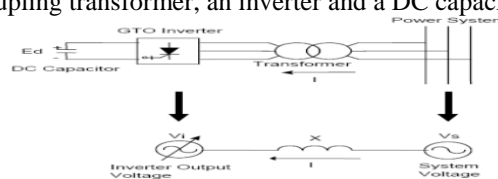

Fig 1 Equivalent circuit of STATCOM

Using the classical equations that describe the active and reactive power flow in a line in terms of V_i and V_s , the transformer impedance (which can be assumed as ideal) and the angle difference between both bars, we can define P and Q .

The angle between the V_s and V_i in the system is δ . When the STATCOM operates with $\delta = 0$ we can see how the active power send to the system device becomes zero while the reactive power will mainly depend on the voltage module. This operation condition means that the current that goes through the transformer must have a $\pm 90^\circ$ phase difference to V_s . In other words, if V_i is bigger than V_s , the reactive will be send to the STATCOM of the system (capacitive operation), originating a current flow in this direction. In the contrary case, the reactive will be absorbed from the system through the STATCOM (inductive operation) and the current will flow in the opposite direction. Finally if the modules of V_s and V_i are equal, there won't be neither current nor reactive flow in the system as shown in fig 2.

Thus, we can say that in a stationary state Q only depends on the module difference between V_s and V_i voltages. The amount of the reactive power is proportional to the voltage difference between V_s and V_i .

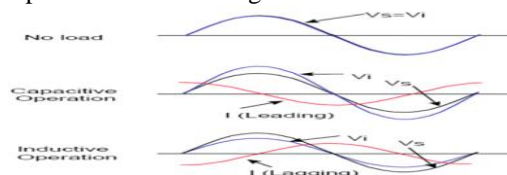

Fig 2 Operation Characteristics of STATCOM

III. CHARACTERISTICS OF STATCOM AND SVC

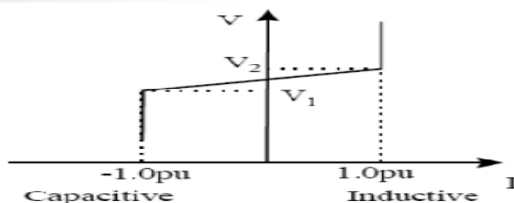

Fig 3 V-I Characteristics of STATCOM

The STATCOM smoothly and continuously controls voltage from V_1 to V_2 as shown in fig 3. However, if the system voltage exceeds a low-voltage (V_1) or high-voltage limit (V_2), the STATCOM acts as a constant current source by controlling the converter voltage (V_i) appropriately.

With the active power constraint imposed, the control of the STATCOM is reduced to one degree of freedom, which is used to control the amount of reactive power exchanged with the line. Accordingly, a STATCOM is operated as a functional equivalent of a static var compensator; it provides faster control than an SVC and improved control range. Each GTO converter generates a voltage that is stepped up by a line-side-series-connected multi-stage converter transformer. The converter transformer enables the build-up of a sine-wave voltage in both magnitude and phase. Because STATCOMs with multi-stage converter transformers do not generate significant internal harmonics, they generally require minimal or no harmonic filtering. If the number of firing pulses for the GTOs is increased (i.e., pulse-width modulation (PWM) order), the harmonics are further decreased.

Static Var Compensator is “a shunt-connected static Var generator or absorber whose output is adjusted to exchange capacitive or inductive current so as to maintain or control specific parameters of the electrical power system (typically bus voltage)”. SVC is based on thyristors without gate turn-off capability. The operating principal and characteristics of thyristors realize SVC variable reactive impedance. SVC includes two main components and their combination: (1) Thyristor-controlled and Thyristor-switched Reactor (TCR and TSR); and (2) Thyristor-switched capacitor (TSC).

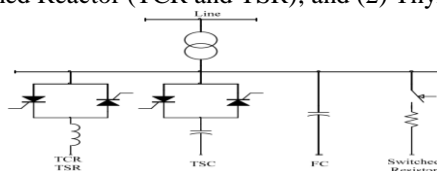

Fig 4 Static VAR Compensators (SVC)

IV. SIMULATION AND RESULTS

STATCOM has a rating of ± 100 MVA. This STATCOM is a phasor model of a typical three-level PWM STATCOM. STATCOM is having a DC link nominal voltage of 40 KV with an equivalent capacitance of 375 μ F. The circuit diagram without compensation is shown in Figure 5. In this circuit the power is directly measured in the 600km long transmission line at the three stages like sending end, middle and receiving end and also tabulated the result of voltage and reactive power in table 1. The circuit diagram when STATCOM is connected at the middle of the long transmission line is shown in fig 6.

Similarly the connections are made when the STATCOM is connected at the sending end and receiving end of the long transmission line. In this circuit the voltage and reactive power are directly measured and tabulated the result in table 3. For comparison purpose, the result is tabulated in table 2 with SVC (replacing STATCOM) at different positions.

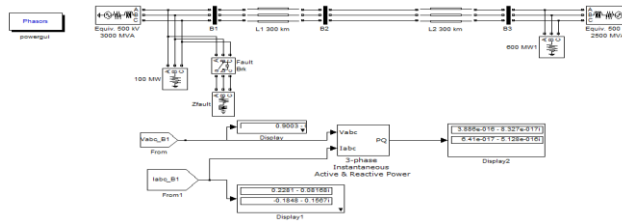

Fig 5 Simulink model of uncompensated transmission line

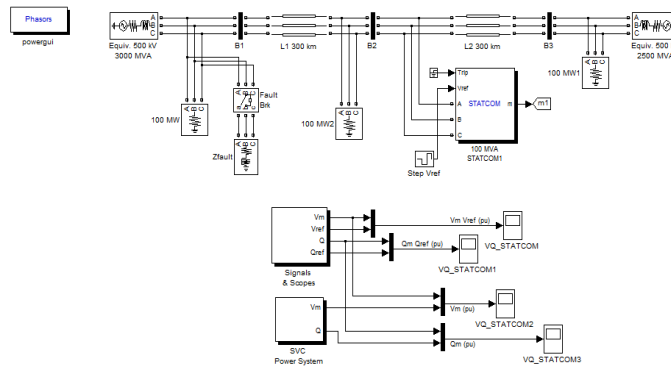

Fig 6 Simulink model of compensated transmission line

Table 1

Simulink data of uncompensated transmission line

UNCOMPENSATED	VOLTAGE (PU)	REACTIVE POWER (PU)
SENDING END	0.903	6.41E-17
MIDDLE	0.691	2.884E-16
RECEIVING END	0.385	5.76E-16

Table 2

Simulink data of SVC in transmission line

SVC	VOLTAGE (PU)	REACTIVE POWER (PU)
SENDING END	0.96	-0.9357
MIDDLE	0.98	-0.5944
RECEIVING END	0.98	-0.9798

Table 3

Simulink data of STATCOM in transmission line

STATCOM	VOLTAGE (PU)	REACTIVE POWER (PU)
SENDING END	0.98	4.72E-12
MIDDLE	1.002	0.06
RECEIVING END	0.99	-0.02

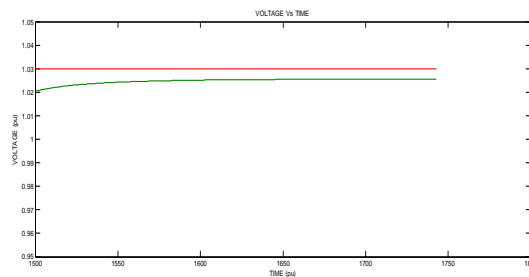

Fig7. Voltage of STATCOM at middle of transmission line

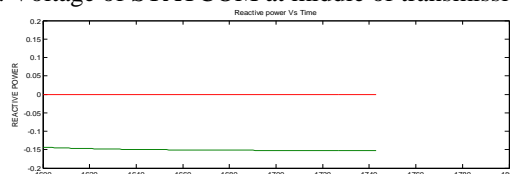

Fig8. Reactive power of STATCOM at middle of transmission line

When STATCOM is placed at the middle of the transmission line the voltage and the reactive power obtained are 1.002 pu and 0.060 pu respectively and they are improved when compared with all the locations of SVC.

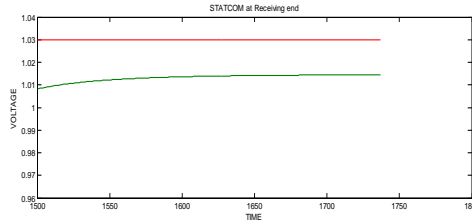

Fig9. Voltage of STATCOM at receiving end of transmission line

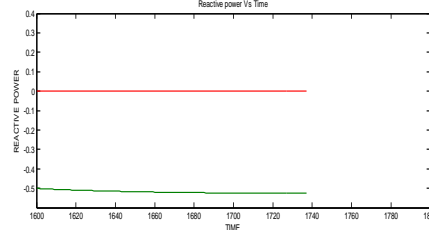

Fig10. Reactive power of STATCOM at receiving end of transmission line

When STATCOM is placed at the receiving end of the transmission line the voltage and the reactive power values are 0.99 pu and -0.02 pu respectively. The reactive power value is not compensated when compared with the other ends of the long transmission line. But by comparing, it is clear that the reactive power is compensated (-0.02 pu) with STATCOM when compared to SVC (-0.9798 pu).

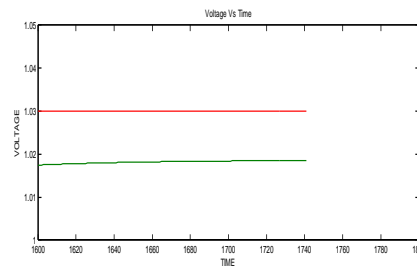

Fig11. Voltage of STATCOM at sending end of transmission line

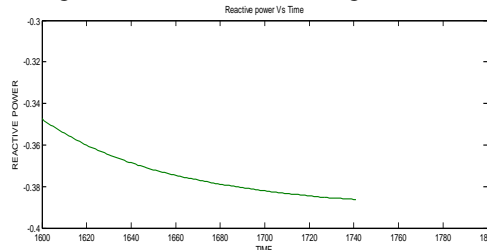

Fig12. Reactive power of STATCOM at sending end of transmission line

When STATCOM is placed at the sending end of the transmission line the voltage profile and reactive power values are 0.98 pu and 4.72×10^{-12} pu respectively and reactive power is improved when compared with SVC at all locations of the transmission line.

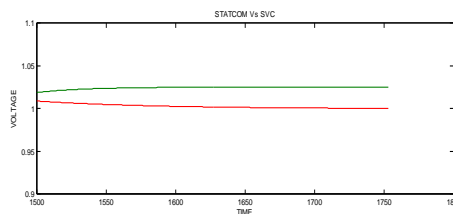

Fig13. Voltage of STATCOM and SVC at middle of transmission line

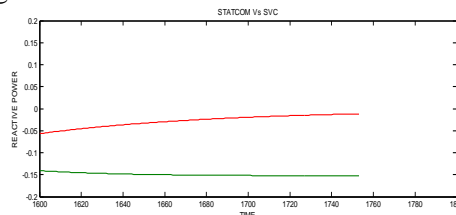

Fig14. Reactive power of STATCOM and SVC at middle of transmission line

By observing the values in table 2 and 3, voltage profile is increased with the placement of STATCOM rather than with SVC. The reactive power is compensated much better with the STATCOM when compared with SVC. The voltage profile and the reactive power compensation values are 1.002 pu and 0.06 pu respectively are much improved at middle of the transmission line with the placement of STATCOM, when compared with other places like sending end, receiving end of the long transmission line. The uncompensated voltage and reactive power values of a long transmission line are also shown in table 1.

V. CONCLUSION

STATCOM and SVC are connected at the various locations such as sending end, middle and receiving end of the transmission line. Based on a voltage source converter, the statcom regulates system voltage by absorbing or generating reactive power. The results are obtained with and without compensation using matlab/simulink environment. The simulation results reveal that the reactive power obtained for STATCOM is better when compared with SVC at the middle of the transmission line. So, the location of STATCOM is optimum when connected at the middle of the long transmission line. The numerical results of the system analysis are elaborated in the tables 1, 2 & 3.

REFERENCES

- [1]. M.Karthikeyan, Dr.P.Ajay-D-Vimalraj "Optimal Location of Shunt Facts Devices for Power Flow Control". IEEE, 2011.
- [2]. Tan, Y.L., "Analysis of line compensation by shunt-connected FACTS controllers: a comparison between SVC and STATCOM", IEEE Transactions on Power Engineering Review, Vol.19, pp 57-58, Aug 1999.
- [3]. Xia Jiang Xinghao Fang Chow, J.H. Edris, A.-A. Uzunovic, E. Parisi, M. Hopkins, L. "A Novel Approach for Modeling Voltage-Sourced Converter-Based FACTS Controllers", IEEE Transactions on Power Delivery, Vol.23(4), pp 2591-2598, Oct 2008.
- [4]. Chandrakar, V.K. Kothari, A.G. "Optimal location for line compensation by shunt connected FACTS controller", The Fifth International IEEE Conference on Power Electronics and Drive Systems", Vol 1, pp 151-156, Nov 2003.
- [5]. Bebic, J.Z. Lehn, P.W. Iravani, M.R. "The hybrid power flow controller - a new concept for flexible AC transmission", IEEE Power Engineering Society General Meeting, DOI-10.1109/PES.2006.1708944, Oct 2006.
- [6]. Johnson, B.K. "How series and combined multiterminal controllers FACTS controllers function in an AC transmission system", IEEE Power Engineering Society General Meeting, Vol.2, pp 1265-1267, June 2004.
- [7]. Shankaralingappa, C.B. Jangamashetti, S.H. "FACTS Controllers to Improve Voltage Profile and Enhancement of Line Loadability in EHV Long Transmission Lines", International IEEE Conference on POWERCON, pp 1-5, Oct 2008.
- [8]. K.R. Padiyar N. Prabhu "Design and performance evaluation of subsynchronous damping controller with STATCOM", IEEE Transactions on Power Delivery, Vol.21(3), pp 1398-1405, July 2006.
- [9]. Zarghami, M. Crow, M.L. "Damping inter-area oscillations in power systems by STATCOMs", 40thNorth American Symposium 2008, pp 1-6, 978-1-4244-4283-6, Sept 2008.
- [10]. Yap, E.M. Al-Dabbagh, M. Thum, P.C. "Applications of FACTS Controller for Improving Power Transmission Capability", IEEE Conference on TENCON 2005, pp 1-6, Nov 2005.