

## Smart Connect Using Cellular Technology

Ms. Priyanka V. Kampasi, Prof. Y.C. Kulkarni,

<sup>1,2</sup>Bharati Vidyapeeth's College of Engineering/IT, Pune, India

**ABSTRACT:** Technical developments in computer hardware and software make it possible to introduce automation into virtually all aspects of human-machine systems. Automation has made Software applications much more efficient to use. This paper proposes that automation can be applied to desktop sharing in which a system can operate automatically anywhere in the world using GSM technology & VIRTUAL LAN concept.

The proposed system will be used to make the purpose of data access simpler, keeping in mind the needs of the IT industries. Through this system, automated desktop sharing can be implemented with effective cause. Today's desktop conferencing and groupware software often assume a serial work model in which information (pictures, documents, and presentations) are prepared by one person and then disseminated to others for comments, revision, or review. However, many types of collaborative work are much more parallel, with many people viewing, updating, and adding information concurrently across cross-platform display sharing between Mac OS, Windows, and UNIX operating systems. The current EMSL Televiewer prototype supports display sharing of application windows, screen regions, and desktops. This system proposes enhancements to the EMSL Televiewer that will provide collaborative annotations over the display, shared mouse cursors, pointer, high performance data compression, and session recording capabilities. When completed, the EMSL Televiewer will provide researchers and the scientific community a powerful tool that can by itself open up many new avenues for collaboration and will fit well with other tools to provide a comprehensive collaborative environment.

**Keywords:** Cell Phone, Desktop Sharing, Encryption, GSM, Microcontroller.

### I. INTRODUCTION

The concept of Desktop Sharing has revolutionized the work of IT professionals immensely. While sitting at home or while roaming, an IT professional can work on his office computer anytime. The Computer system in the office can be accessed by the employee anywhere. Yes, of Course there are security considerations that must be met. That is, the authenticity of the person requesting access to the workplace computer. Earlier even though a person could remotely access his/her office computer but still he/she required a desktop computer or a laptop. The Goal of designing this application is for the benefit of industry people by allowing them multi-sharing of the computer screen for their assignments through cellular technology like a Cell Phone. It requires a PC with a modem setup. The computer/laptop contains important data or information. This information can be accessed by the user anywhere anytime through her mobile phone. The Cell Phone must be Internet enabled. When a request is send by the cell phone to the respective modem which is received using the GSM

system, it shall respond back by sending an acknowledgment message asking password so as to confirm that an authentic user has made the request.

As soon as the correct password is received as a response to the request, the system shall generate 4-digit conformation code for establishing the connectivity. As soon as the system is connected, the data transfer can take place. For providing security to the data transmission, SHA-1 algorithm is used.

The system is basically focused for those people who travel around the globe and need to be consistently connected to their workplace or home at the same time.

The proposed system has a great potential and it will benefit the masses for a long time.

Everybody these days possesses a Mobile Phone. As it is small in size and portable, it become a smarter choice for accessing the remote desktop than a PC or a laptop. This paper proposes the use of Mobile Phones (equipped with Internet features) by the IT professionals to access their office computers after proper authentication check.

The overall system will require hardware components like a Modem, Microcontroller, Microprocessor and a USB Port to accomplish this task. For secure transmission of data between the cellular device and the PC, encryption algorithm (SHA 1) will be used.

Apart from this if ROBOT APIs are used then we can use our Mobile phone as a remote control for switching on or off the lights, adjusting the thermostat of our AC. It could also be used for indicating the temperature in high temperature zones like Nuclear Reactors.

The whole application is divided into modules according to their functionalities. The output of one module is input for the next module. Intended Audience and Reading Suggestions This document is intended for the persons in the following categories Students doing Graduation in Computers. Internal and External guide. Most of the industries need it for their project development.

### II. The SHA-1 hash function

SHA-1 produces a 160-bit message digest based on principles similar to those used by Ronald L. Rivest of MIT in the design of the MD4 and MD5 message digest algorithms, but has a more conservative design. The original specification of the algorithm was published in 1993 as the *Secure Hash Standard*, FIPS PUB 180, by US government standards agency NIST (National Institute of Standards and Technology). This version is now often referred to as *SHA-0*. It was withdrawn by NSA shortly after publication and was superseded by the revised version, published in 1995 in FIPS PUB 180-1 and commonly referred to as *SHA-1*.

SHA-1 differs from SHA-0 only by a single bitwise rotation in the message schedule of its compression function; this was done, according to NSA, to correct a flaw in the original algorithm which reduced its cryptographic security. However, NSA did not provide any further explanation or identify the flaw that was corrected.

Weaknesses have subsequently been reported in both SHA and SHA-1. SHA-1 appears to provide greater resistance to attacks, supporting the NSA's assertion that the change increased the security.

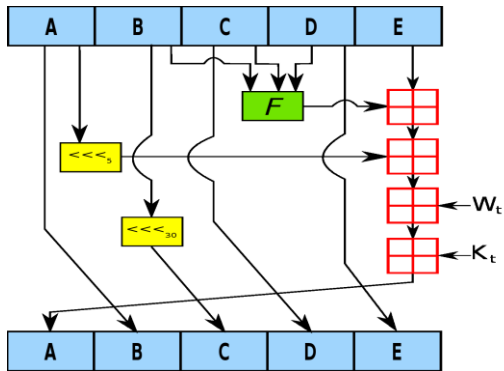

One iteration within the SHA-1 compression function:  
 A, B, C, D and E are 32-bit words of the state;  
 F is a nonlinear function that varies;  
 n denotes a left bit rotation by n places;  
 n varies for each operation;  
 Wt is the expanded message word of round t;  
 Kt is the round constant of round t;  
 Denotes addition modulo 232

### III. LITRATURE SURVEY

Desktop sharing commonly refers to a remote frame buffer technology. Desktop sharing allows a user to send screen data to be drawn elsewhere and receive input remotely. Its applications vary from remote system administration to accessing virtual machines. There has been much research concerning the use of desktop sharing as a platform for collaboration. A few useful features appear in several papers.

The BASS Application Sharing System established the idea of applying a secondary protocol to re-encode video and stream it separately from the frame buffer for any video playing on the screen. Additionally the sharing system supports per-application sharing by removing all non-application specific information from the remote frame buffer. In one system researchers enhanced the Virtual Network Computing (VNC) protocol by adding an additional layer of authentication to allow for view-only or normal interactivity connections.

Systems that support multicast (multiple people only seeing one screen) tend to use the Binary Floor Control Protocol to determine controllability of the screen at any one point in time. There are also other papers of interest that cover non-desktop sharing collaboration. For example, research on remote pair programming, where two users work on the same code at the same time using shared cursors and synchronized codebases, differs from desktop sharing because both users are still seeing different desktops. Instead of actually visualizing the other collaborator's desktop, a user of the Sangam tool has a synchronized view and cursor with the other collaborators. This approach works well in very specialized environments such as programming Integrated Development

Environments (IDEs) but lacks usability in more general scenarios. Unfortunately no hard research has been done on the efficacy of the technique but it is important to remember that desktop sharing is just one facet of collaboration technology.

Help desk is a generic name typically associated with an end-user support center. Prior to the creation of a dedicated help desk, end-users often resorted to contacting a friend or colleague for assistance. Today's savvy technology managers realize that it is critical to transform outdated "help desks," which rely primarily on telephone communications, into efficiently managed "service desks" that efficiently and economically accommodate multiple forms of interaction - from voice and data to email and instant messaging. They also understand that by transitioning to self-assist and remote incident resolution they can reduce service desk operational costs by half, while dramatically improving the quality of service provided.

Although the telephone is the preferred method of seeking support, end-users can encounter frustration when calling the help desk. End-users often lack confidence that they will be able to adequately describe the issue they are experiencing or fear embarrassment for their lack of application and or computer knowledge and skills. This can lead to confusion and misinterpretation for the support specialist as they attempt to resolve the issue. Concern over a language barrier is a potential drawback of phone support as well. The end-user may become frustrated and abandoned the call before their issue is resolved if they're unable to understand a support specialist due to a thick accent.

In order to overcome such problem, the Help Desk can capture the customers desktop and solve the problem themselves.

### 3. SYSTEM ARCHITECTURE

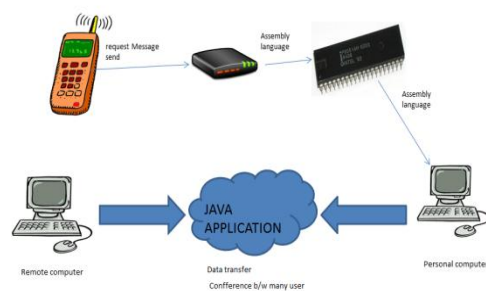

Fig. 1, Overview Of Teleo-desto

A user has to send an SMS by the cell phone to the home server. It will be received through hardware modules like modem, microcontroller and a microprocessor. The system responds back by sending an acknowledgment message asking user to prove his /her authenticity.

Incase of authentic password reception, the system generates a onetime password for the user to establish the connectivity. As soon as the system is connected, the data transfer can take place. For providing security to the data transmission, a very powerful encryption algorithm is used.

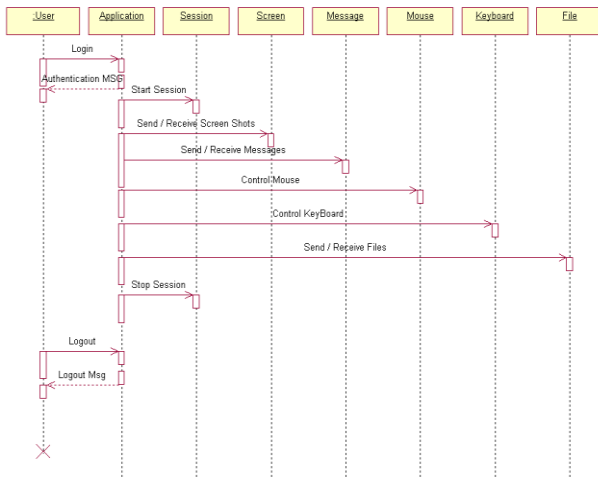

Fig. 2, Sequence Diagram

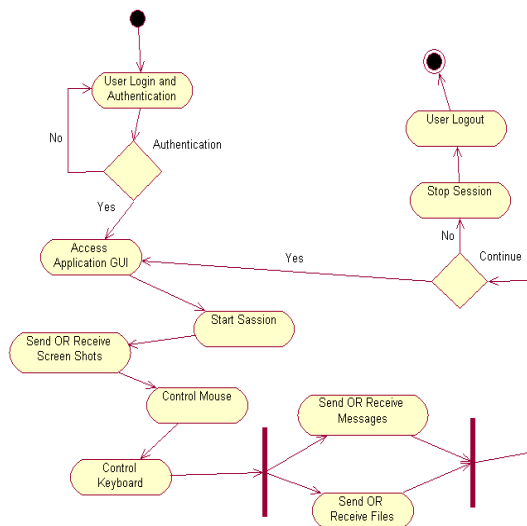

Fig. 3, Use case diagram

#### IV. ADVANTAGES

- 4.1 Anyone can access data from a PC anywhere and anytime by simply sending an SMS.
- 4.2 It saves money by lowering your monthly utility bills.
- 4.3 Easy to operate and use as Mobile Phones are extensively used.
- 4.4 Has negligible portability issues as Cell Phones easily fit in pockets.

#### V. DISADVANTAGES

- 5.1 The energy required to run the devices .This problem can be removed by using solar technology to run the system.
- 5.2 Installation will need expertise person the local resident will face a problem in installation.
- 5.3 There is maintenance of this system is required as this is a new technology and have potential risks. Regular checkup of the security and other critical operations are necessary for such new technology.

#### VI. CONCLUSION

In conclusion, we feel that the proposed system has a great potential in revolutionizing the concept of Desktop Sharing. As Mobile phones are small in size and easily portable, they become a smarter choice for accessing the remote desktop than a PC or a laptop. They can be easily carried and handled by their users. They are a smarter means of working on Remote Systems than a traditional desktop computer or a laptop. Also a cell phone can become a remote control for its users in switching on or off the light bulbs or also act as an indicator showing temperature readings in high temperature zones.

#### REFERENCES

- [1] Two Factor Authentication Using Mobile Phones Fadi Aloul,Syed Zahidi, Wassim El-Hajj
- [2] Towards Ubiquitous Computing via Secure Desktop Service Pan-Lung Tsai, Student Member,IEEE, and Chin-Laung Lei, Member , IEEE
- [3] A Herzberg, "Payments and Banking with Mobile Personal Devices", Communications of the ACM, 46(5), 53-59, May 2008
- [4] J. Brainard, A. Juels, R. L. Rivest, "Fourth Factor Authentication": ACM CCS, 168-179,2010
- [5] National Institute on Standards and Technology Computer Security Resource Center, NIST's Policy on Hash Functions, March 29, 2009.
- [6] Niels Ferguson, Bruce Schneier, and Tadayoshi Kohno, Cryptography Engineering (http:// www.schneier.com/ book-ce.html), John Wiley & Sons, 2010.
- [7] A. Josang and G. Sanderud, "Security in Mobile Communications: Challenges and Opportunities" in Proc. Of the Australian information security workshop condence on SACSW frontiers, 43-48, 2003.