

Efficient Energy Management System with Solar Energy

P. Nagalaxmi¹, M. Veda Chary²

¹II Year M. Tech (Embedded Systems), ²Associate Professor
Dept of ECE, CMR College of Engineering and Technology, Hyderabad, AP-India

ABSTRACT: As decaying of fossil fuels and scarcity of electricity generating resources, an alternate methods for generating electricity are highlighted and these methods uses renewable sources like solar power, wind power, tidal energy and so on. Many research companies concentrate on the elemental technologies to generate the power but the energy generated from these resources is not sufficient as the growth of power demands and need efficient and intelligent distribution system to distribute the energy. The intelligent energy distribution management system is developed and the results of managing the distribution of energy which is generated from renewable resources are used effectively as presented and discussed.

Keywords: Efficient energy distribution system, power monitoring device, renewable source, solar panel, Zigbee.

I. INTRODUCTION

An increasing Global warming, currently occurring on this 4.6 billion years old earth, is a very critical issue to be addressed by the modern society that has been enjoying economical growth by consumption of fossil energies. Since the Industrial Revolution in Great Britain, much carbon dioxide (CO₂) has been emitted as a result of the combustion of petroleum and coal. In the past 200 years, the carbon dioxide concentration in the atmosphere has increased by as much as 25%. Now the entire earth is, so to speak, situ three of the most prominent issues facing the world today are escalating climate change, energy security and meeting the increasing global demand for electrical energy generated from renewable sources.

The renewable energy is growing technology for meeting the demands of energy consumption to solve the problems of fossil fuels and at the same time reduce the pollution in the atmosphere. In case of fossil fuels once it is used that can't regenerated means it is converted into electricity and is used by consumers. Where as in case of renewable sources the energy generated is unlimited. Hence the importance of renewable energy is becoming a great technology and today the world seeing to develop these technologies.

Now a day many companies are seeing that to increase the efforts on development of renewable sources by constructing smart grids having sustainable growth and connecting those smart grids to the commercial electricity grids. The renewable energy sources are of different forms like solar, wind, tidal ect. But the problems with this technology are that the energy generated from renewable sources may vary with time and climatic conditions, means these generate indefinite amount of energy but hard expect the constant generation [1].

In this paper, introduced an efficient energy distribution system to distribute the energy generated from the renewable sources [2]. In order to meet the current problems the energy generated from the renewable sources to maintain it constant, it was connected to a battery and inverter. In this research we have implemented a prototype system for the ideas. The preliminary tests show that this approach is promising for real applications. A case study on the basis of the California residential-sector shows that at 10% penetration levels for households with a 4-kW solar PV panel with a 0.5-kW.h battery, the daily systems cost savings per household could be over \$5 a day in August[3].

In section II related work in renewable source technologies were discussed. Proposed efficient distribution system is mentioned in section III. Implementation of the system is then presented in section IV. Experiment results are placed in section V. Finally a brief conclusion and future work are given in section VI.

II. RELATEDWORK

Renewable sources are also called Echo friendly technologies are very important due to their pollution free energy generation and having sustainable growth. There are many sources of energy that are renewable and considered to be environmentally friendly and harmless natural processes [4]. These sources of energy provide an alternate 'cleaner' source of energy, helping to negate the effects of certain forms of pollution. All of these power generation techniques can be described as renewable since they are not depleting any resource to create the energy. While there are many large-scale renewable energy projects and production, renewable technologies are also suited to small off-grid applications, sometimes in rural and remote areas, where energy is often crucial in human development.

But the disadvantage with the renewable sources is that their power generation varies with climatic condition and hourly based. To store this unsteady generated energy from renewable sources required a huge, efficient battery and inverter [5], and these are necessary to connect to the power grid. In case of solar power systems variation in the power generation is largely depends on weather and season. Hence every renewable energy system requires storage systems. However the storage systems also have some limitations in the point of installation and return of investment. So to avoid this, in this paper we propose a management system that effectively distributes the energy generated from renewable sources and maximize the efficiency.

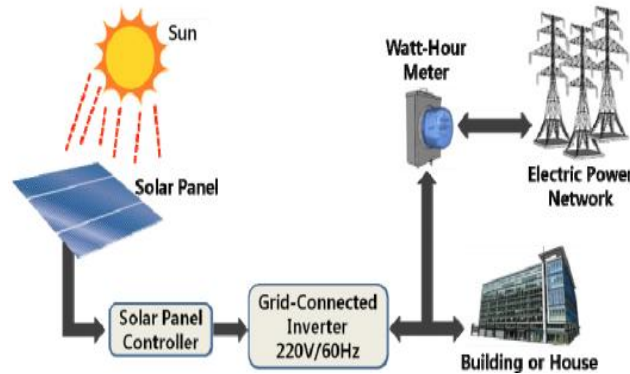

Fig.1. Structure of general renewable energy system

In this paper, we propose an efficient distribution management system, the combination of elemental technologies of renewable sources with commercial electricity maximize the efficiency.

III. INTELLIGENT SYSTEM

Intelligent energy distribution system is the most important in order to determine how effectively the power generated from renewable sources are distributed. The system decides when to use the energy stored in the battery, that is whenever the power generated from the commercial electricity grid is very low then the switching action takes place, switches to the solar grid. If the energy generated from the solar panel is sufficient then power supplied as usual as the commercial grid otherwise controlling action takes place. The energy stored in the battery is always compared with the preset levels and if it is low then it communicates with control room to take necessary steps. According to the energy levels in the stored battery the controlling of devices takes place.

If the energy level is below the first preset level then the power that goes to the least priority devices are automatically shut off and the high priority devices are run and if the energy is below that then the next priority devices are shut off and allows to run only the highest priority devices giving a signal to take the necessary actions.

The power monitoring device has three power sockets to measure the power consumption of devices and Zigbee network module, that can transmit the status of the battery and receives the control signals to control the power through the devices. Fig.2 shows the basic block diagram for intelligent and efficient distribution system consisting of microcontroller unit, relay control unit; Zigbee communication; user interface, power sensing unit (energy meter) and power supply exist in the system. The energy meter measure the power consumption, consisting of a CT sensor converted to a current value which can handled in the MCU. The renewable energy management system manages the generated power and battery charging conditions in the solar power generator. The power management methods are of two types, efficiency oriented and user oriented. In the efficient method the generated power and the battery charging conditions are transmitted to the smart power management system and it is compared with the power consumption data stored in the MCU. But the problem with this technique is that it finds only the optimal time to use the charging battery for decreasing power consumption and electric charges.

In this paper we proposed a user oriented method to run the devices by setting the priorities and run the device having highest priority for a long time compared to the devices having least priority, which increases the efficiency in the point of user. The block diagram in fig.2 having three sockets is nothing but three loads. The intelligent system efficiently distributes the power generated from the solar panel to these prioritized loads depending upon the status of the battery.

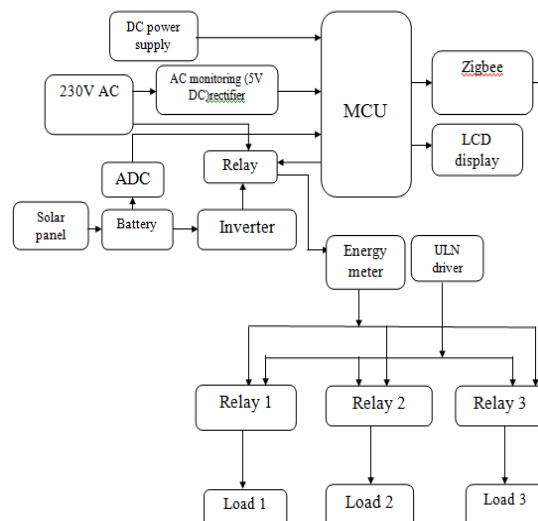

Fig.2 Hardware architecture of intelligent distribution system

IV. IMPLEMENTATION

In the previous section we describe the efficient intelligent energy distribution system. Now we can see how to implement this system, when the electricity generated from the thermal plants is enough then it is connected to the connected to the energy meter through the power grid network, otherwise when the this electricity is not available then the energy generated from the solar panel is connected to the energy meter trough the grid inverter and distributed to the devices according to the prioritization which increases the efficiency of the solar power. Always the power requires is compared with the stored value

in the battery and generates the control signals according to conditions specified.

As the consumption of power increases, the energy stored in the battery decreases causes that no longer the devices operate with the solar energy. In order to increase the efficiency of the solar system it is required to distribute the energy intelligently, sends a control signal from the control room to turn off the least priority devices and keep on monitoring the battery status. If the battery value reaches the threshold value which is set for safe operation runs only the highest priority device making all remaining devices turn off.

Fig.3 shows the efficient distribution system that distributes the power generated from the solar panel. To make the switching action between commercial electricity and solar power a relay is placed. To monitor the electricity from power grid network, 5v input is given to the MCU whenever the monitor pin reads 0V then relay connects the solar system to the energy meter and it displayed on the LCD display and on the PC in control room. Zigbee provides the communication between the control station and distribution system. The control commands are given remotely to control power going to the devices depending on the battery status.



Figure 3: Efficient Distribution System

The algorithm is as follows:

- Step1: Initialization of devices.
- Step2: Initially both AC and Inverter sections are in ON condition.
- Step3: Devices are run with AC power
- Step4: In microcontroller one pin is programmed to monitor the AC power, when it is goes off, the relay is connected to the inverter.
- Step5: Now the solar energy is connected to the meter
- Step6: In micro controller the stored energy is always compared with presetting levels
- Step7: If the stored energy is greater than the power Consumption then the least priority device is automatically turn off.
- Step8: Otherwise highest priority load will run by turning off other loads.
- Step9: Whenever the AC power is available then the relay connects it to the energy meter.
- Step10: Stop the process.

V. EXPERIMENT RESULTS

The results shows that, when the power from both power plant and solar system are present then the efficient distribution system connects the energy meter to power line generated from power plant and runs all the devices. Otherwise the remote control station sends the command signal to connect the solar system to the energy meter and compares the battery status continuously to run the prioritized devices.

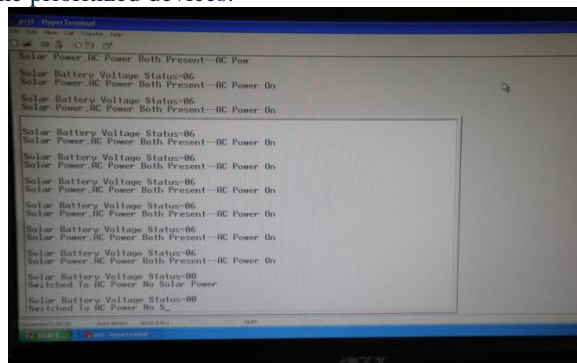

Figure 4: Controlling from remote station

Control station that is remotely located, communicates with the efficient system through the Zigbee and it displays the results like on PC like, when AC power and Solar power present AC power ON, Otherwise AC power off and solar power present and also display the voltage in the inverter. According to the battery status it operates the loads given in the following table in this for demo purpose three loads are considered.

Battery status	Loads condition
Between 12V-10V	Three loads are run
Between 10V-08V	Load -3 turn off(least priority device)
Between 08V-06V	Load-1 only ON(highest priority),turns off reaming devices
Below 6V	Along with running the highest priority device gives an alert signal

Table 1: Load Distribution

VI. CONCLUSION

In this paper we proposed a system to distribute the power generated from renewable sources efficiently. By increasing the capacity of solar panel and efficiency of the battery it is possible to construct a solar grid parallel to the commercial grid which solves the problems of electricity in future and it can be distributed effectively to the rural and urban areas which solves the problems of electricity. But the problem with this system is that to require huge inverter to store the largely variable solar energy and its maintenance. This can be overcome by constructing solar grids parallel to the existed grids by the government.

REFERENCES

- [1] M.M.Amin and O.A. Mohammed," development of high performance Grid connected wind energy conversion systems for optimum utilization of variable speed wind Turbines" *Sustainable energy. IEEE transaction on*, vol 2, pp 235-245, 2011
- [2] M.B .Nissen" high performance development of distribution generation". *Potentials, IEEE*, vol 28, pp 25-31, 2009.
- [3] Huang, S., Xiao, J., Pekny, J., Reklaitis, G., and Liu, A. (2012). "Quantifying System-Level Benefits from Distributed Solar and Energy Storage." *J. Energy Eng.*, 138(2), 33–42.
- [4] J. Lee, B. Han and K.Chol, "High efficiency grid tied power conducting system for fuel cell power generation," *power electronics and ECE asia (ICPE&ECCE),2011 IEEE 8th international conference on 2011,pp,1492-1497.*
- [5] A.O. Converse, "Seasonal energy storage in a renewable energy system" *proceedings of IEEE*, vol.100, pp.401-409, 2012.

Bibliography:



P. Nagalaxmi, received her B. Tech degree in Electronics & Communication Engineering from JNTU, Hyderabad, currently pursuing M. Tech in Embedded systems from JNTU Hyderabad



M. Veda Chary received his M. Tech degree in Electronics & Communication Engineering from JNTU, Hyderabad, currently working as an Associate Professor, ECE in CMR College of Engineering & Technology, Hyderabad.