

Matlab Simulation And Comparison Of Single Phase To Three Phase Converter Fed Induction Motor Drive Using One And Two Rectifier

Ashish Dongre¹, Sanjay Dhamse²

^{1,2} (Electrical Engineering Department, Government College of Engineering Aurangabad, India)

Abstract: This paper presents MATLAB simulation and comparison of three phase induction motor drive supplied from single phase supply with one rectifier and two rectifiers systems. To meet the new harmonic regulation produced by converters both system incorporates an active input current shaping feature that results in sinusoidal input current at close to unity power factor. Even with the increase in the number of switches, the total harmonic distortion in supply current of the parallel connected two rectifier system is lower than that of a conventional one. The model of the system is developed in MATLAB software. All simulation results and comparison are presented as well.

Keywords: AC to DC to AC converter, high power factor converters, parallel converter, Vector control.

I. INTRODUCTION

In many villages only single phase supply is available. Farming, residential appliances require motors of different type for various operations such as pumping, grinding, material movement *etc.* Motors used in such operations may be rated in kilo watt power range and single phase motor is not suitable for such higher power ratings. Further three phase motors have many advantages over single phase motors in terms of machine efficiency, power factor, and torque ripples. The idea of operating a three phase motors from single phase supply is not new [1]-[3].

Conventionally a three phase induction motor drive consists of a front end full bridge controlled rectifier, dc link capacitor and an inverter as shown in figure 1. It consists of maximum ten switches. This type of configuration requires higher power rating switches in rectifier compared to inverter side [4]. Whereas a parallel connected system consists of a parallel connected full bridge front end controlled rectifier, dc link capacitor bank and a regular six-switch pulse width modulated (PWM) inverter to power a three-phase induction motor from a single-phase ac mains. The block diagram of parallel rectifier system is shown in figure 2. This parallel connected rectifier configuration in all consists of 14 switches. Due to parallel connection the power rating of the rectifier switches is reduced. There has been a considerable increase in the use of parallel converters to improve the power capability, reliability, efficiency, redundancy, and to decrease the cost.

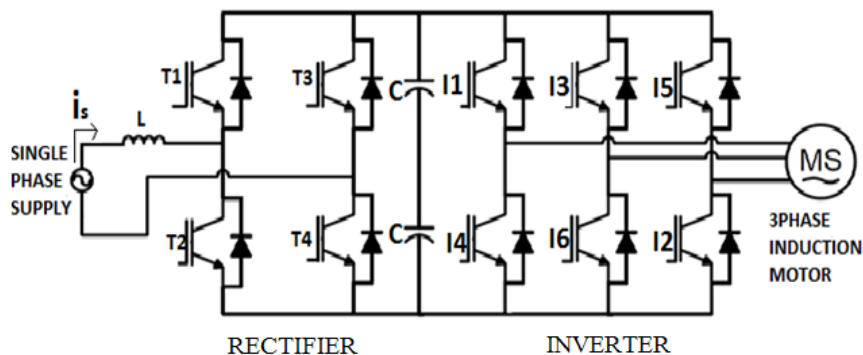

Figure 1: Conventional single phase to three phase induction motor drive

New regulations impose more strict limits on current harmonics injected by power converters [5]. These limits can be achieved with the help of pulse width-modulated rectifiers. These PWM converters, consists of power switches like insulated gate bipolar transistors (IGBTs), gate-turn-off thyristors (GTOs), or integrated gate

controlled thyristors (IGCTs) in the power circuit of the rectifier to change actively the waveform of the input current, reducing the distortion [6]-[7].

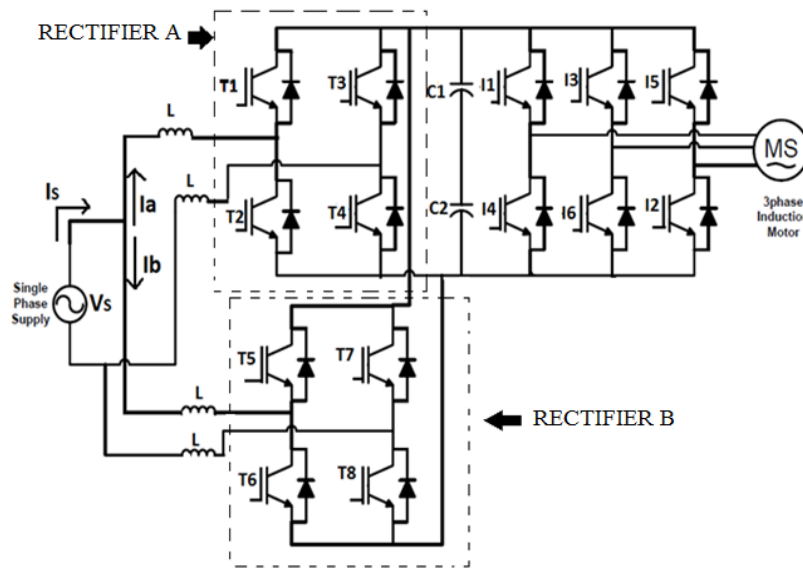

Figure 2: Parallel rectifier connected single phase to three phase induction motor drive

II. Two Rectifier System

The two rectifier system as shown in figure 2 (control circuit for rectifier and inverter is not shown) consist of parallel connected front end rectifier supplied from single phase supply, input inductors, dc link capacitor bank and an inverter whose control signals are generated from vector control method which is discussed later in this paper. Upper rectifier is made up of switches T_1, T_2, T_3 and T_4 and lower rectifier is made up of switches T_5, T_6, T_7 and T_8 . These two rectifiers are connected in parallel. The three phase inverter is composed of three legs having switches $I_1, I_2, I_3, I_4, I_5,$ and I_6 . The dc link capacitor banks which are connected between rectifiers and inverter helps in removing the ripple content of rectifier output. All switches are IGBT switches. Three phase induction motor is supplied from the three phase inverter output. Considering all the supply inductor equal the equations of the parallel connected configuration can be given as

$$\text{Supply current} \quad i_s = i_a + i_b \quad (2.1)$$

$$\text{Output voltage} \quad V_o = V_a + V_b \quad (2.2)$$

$$\text{Rectifier A voltage} \quad V_a = V_s - 2(r + pl_a)i_a \quad (2.3)$$

$$\text{Rectifier B Voltage} \quad V_b = V_s - 2(r + pl_b)i_b \quad (2.4)$$

Where $p = \frac{d}{dt}$ & r & l represents resistance and inductance of the inductor

III. Rectifier Circuit Working Principle and MATLAB Implementation.

3.1. Working Principle of PWM rectifier

To understand the working, consider the conventional circuit of fully controlled single phase PWM rectifier as shown in figure 3 below. It consists of four controlled power switches with anti-parallel diode. For the proper working of this rectifier the output voltage V_o must be greater than input voltage V_s any time [7]. This rectifier can work in two or three levels. The possible combination is as follows.

1.	$T_1=T_4=ON$ $T_2=T_3=OFF$	$V_{PN} = V_o$	Fig3.2(a)
2.	$T_1=T_4=OFF$ $T_2=T_3=ON$	$V_{PN} = -V_o$	Fig3.2(b)
3.	$T_1=T_3=ON$ $T_2=T_4=OFF$	$V_{PN} = 0$	Fig 3.2(c)

And the voltage across inductor can be given as

$$V_l = L \frac{di_s}{dt} \tag{3.1}$$

$$V_l = V_{s(t)} - KV_o \tag{3.2}$$

Where $K= 1, - 1$ or 0 .

If $k=1$ then the inductor voltage will be negative, so the input current will decrease its value.

If $K=-1$ then the inductor voltage will be positive, so the input current will increase its value.

If $K=0$ the input current increase or decrease its value depending on V_s . This allows for a complete control of the input current [7].

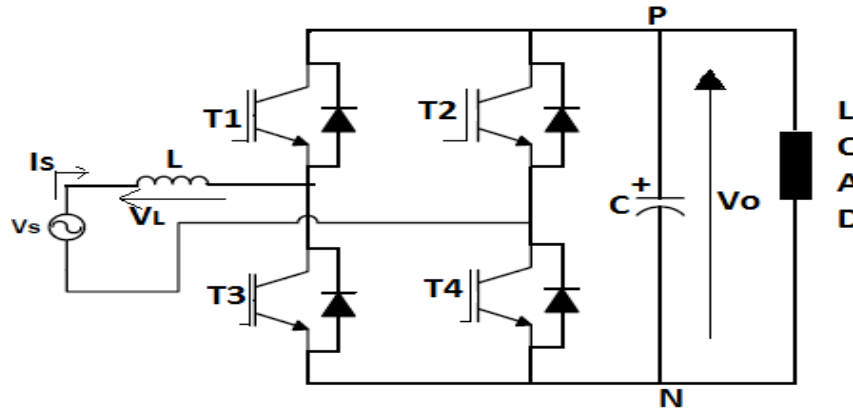

Figure 3.1: Single-phase PWM rectifier power circuit

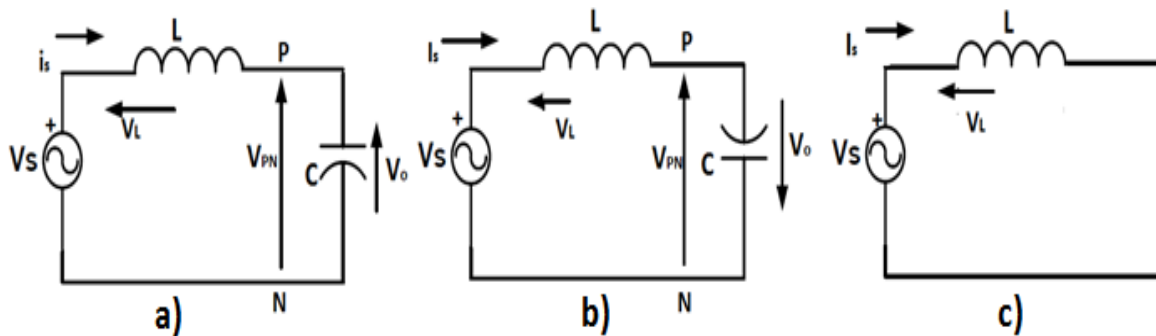

Figure 3.2: Single-phase PWM rectifier power circuit

a) $T_1=T_4=ON$ b) $T_1=T_4=OFF$ c) $T_1=T_3=ON$

3.2. Control Scheme in MATLAB

The main objective of PWM rectifier is to maintain dc link voltage constant and to maintain input power factor close to unity. The dc-link voltage V_c is adjusted to its reference value V_c^* using the standard PI controller. This controller provides the amplitude of the reference supply current I_s^* as shown in figure 4.1. To control the power factor and harmonics in the supply side, the instantaneous reference current I_s^* is synchronized with voltage V_s , as given in the voltage-oriented control (VOC) for three-phase system [8]-[9]. This synchronization is obtained by a phased locked loop (PLL) scheme in MATLAB. The reference currents I_a^* is again given to the controller which defines the input reference voltages V_a^* and then it is compared with the triangular wave to obtain the gating signals for rectifier as shown in figure 4.2. This scheme can be further extended to two rectifiers system. The only thing which needs to be done in two rectifier system is to divide grid current equally to obtain pulses for both the rectifiers.

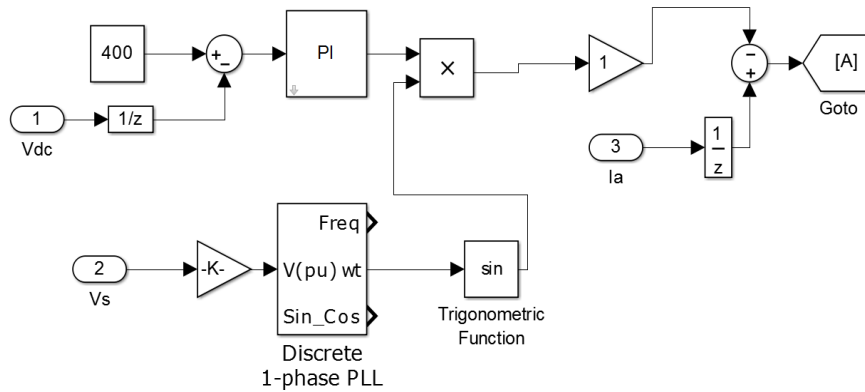

Figure 4.1: Control circuit of rectifier (part1)

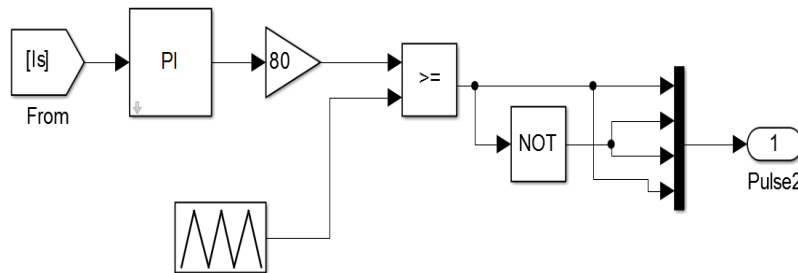

Figure 4.2: Control circuit of rectifier (part2)

IV. Vector Control Induction Motor

The three phase induction motor is fed by current controlled inverter. The control signals for inverter are derived from vector control method which helps in controlling the motor. Figure 7 shows the block diagram of vector controlled induction motor.

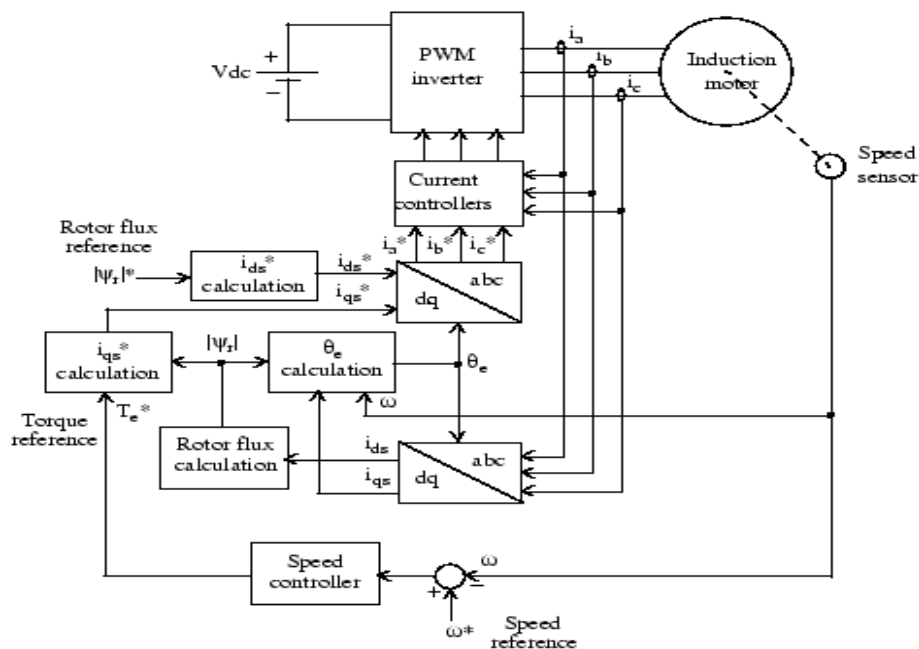

Figure 5: Block diagram of vector control induction motor

In vector control the motor speed ω is compared to the reference speed ω^* and the error is processed by the speed controller to produce a torque command T_e^* . The stator quadrature axis current reference i_{qs}^* is calculated from torque reference T_e^* using equation (4.1). The flux component of current i_{ds}^* for the desired

rotor flux is calculated from equation (4.4). The rotor flux position θ_e required for coordinates transformation is generated by integrating the rotor speed ω_m and slip frequency ω_{sl} given by equation (4.5). The reference quadrature axis i_{qs}^* and direct axis i_{ds}^* current are converted into three reference currents i_a^* , i_b^* , i_c^* for the current regulators by two phase to three phase transformation [10]. The regulators process the measured actual and reference currents to produce the inverter gating signals.

$$i_{qs}^* = \frac{2}{3} \cdot \frac{2}{p} \cdot \frac{L_r T_e^*}{L_m \psi_r} \quad (4.1)$$

Where

$$\psi_r = \frac{L_m \cdot i_{ds}}{1 + \tau_r \cdot s} \quad (4.2)$$

And

Rotor time constant is given by

$$\tau_r = \frac{L_r}{R_r} \quad (4.3)$$

$$i_{ds}^* = \frac{\psi_r^*}{L_m} \quad (4.4)$$

$$\theta_e = \int (\omega_m + \omega_{sl}) dt \quad (4.5)$$

The slip frequency ω_{sl} can be calculated by

$$\omega_{sl} = \frac{L_m R_r}{\psi_r L_r} i_{qs}^* \quad (4.6)$$

Figure 6 shows the block diagram of vector control method implementation in MATLAB. Internal structure of each block of vector control is shown in figure 7.

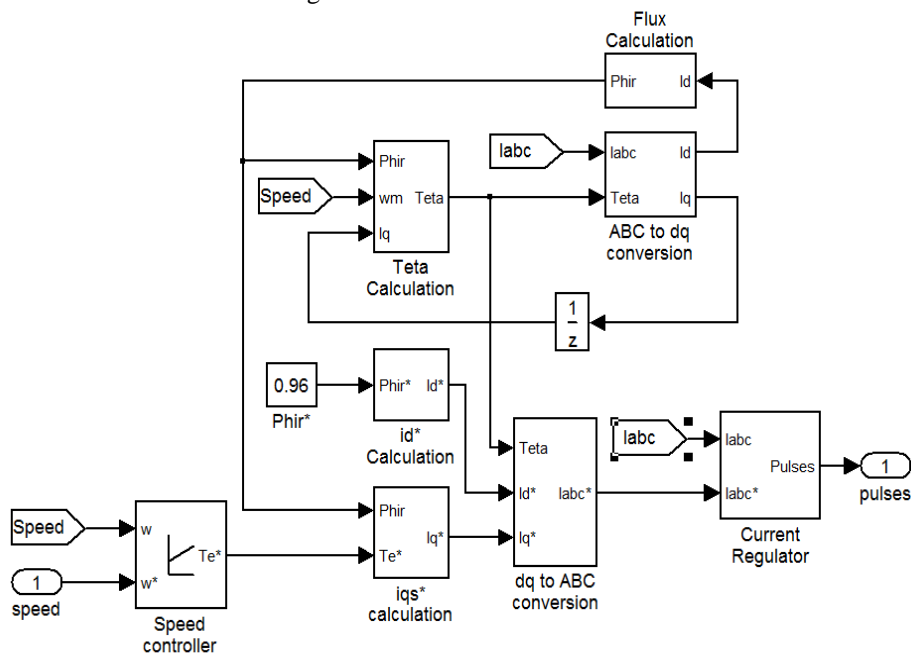

Figure 6: Block diagram of vector control in MATLAB

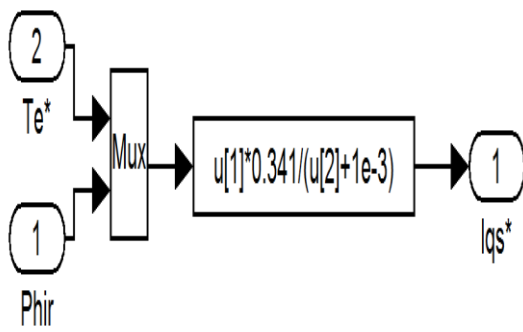

Figure 7.1: i_{qs}^* Calculation

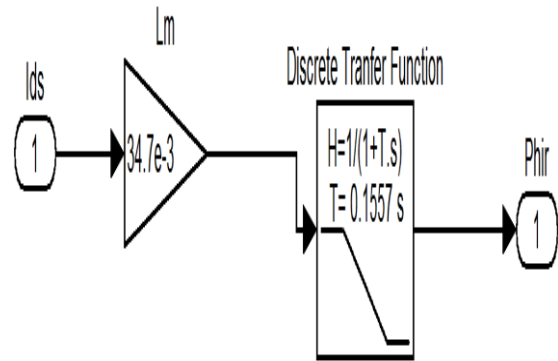

Figure 7.5: ψ_r or Phir Estimation

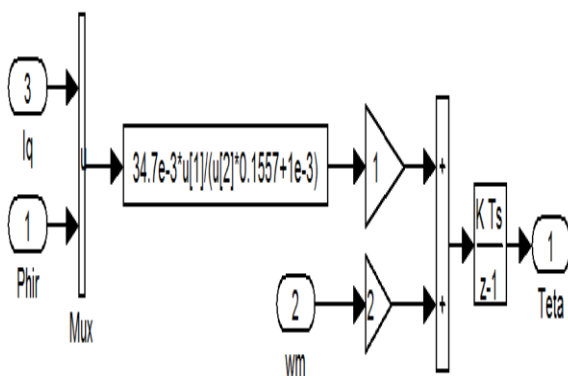

Figure 7.2: Theta or Θ_e Calculation

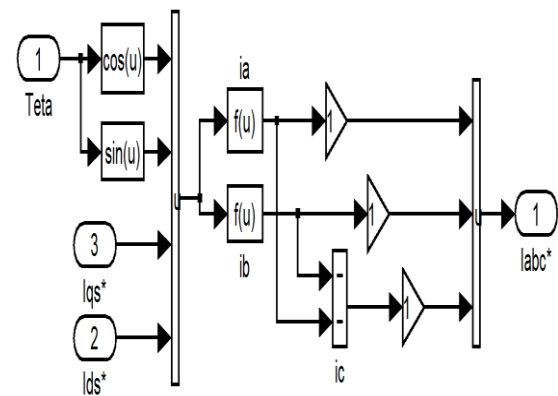

Figure 7.6: Two phase to three phase transformation

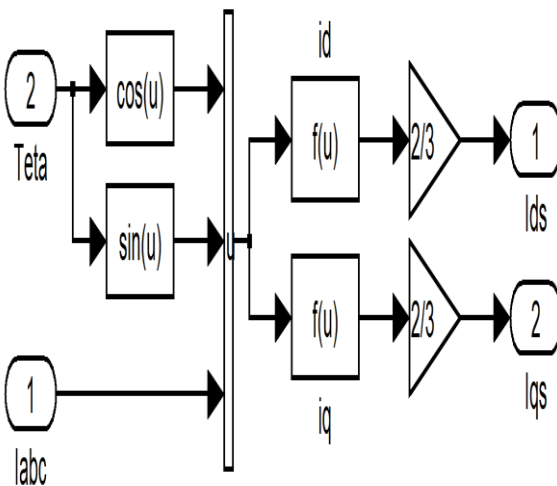

Figure 7.3: Three phase to two phase Transformation

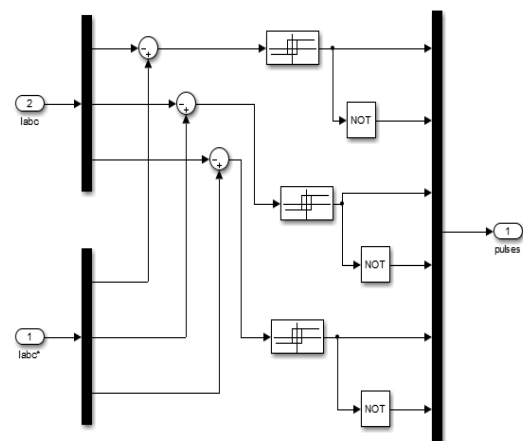

Figure 7.7: Hysteresis current controller

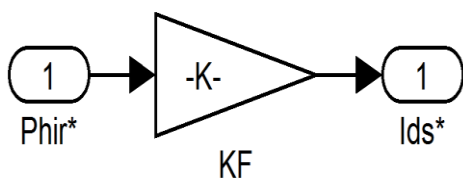

Figure 7.4: i_{ds}^* Calculation

Motor Used in Modeling

1 Hp, 3 phase squirrel cage induction motor		
Parameters		Value
R_s, L_{ls}	Stator resistance and leakage inductance	0.087 Ω , 0.8e-3H
L_m	Magnetizing inductance	34.7e-3H
p	Number of pole pairs	2
R_r, L_{lr}	Rotor resistance and leakage inductance	0.228 Ω , 0.8e-3H
F	frequency	50 Hz
V_{L-L}	Line to line voltage	400v (Rms)

V. Complete System Model In MATLAB

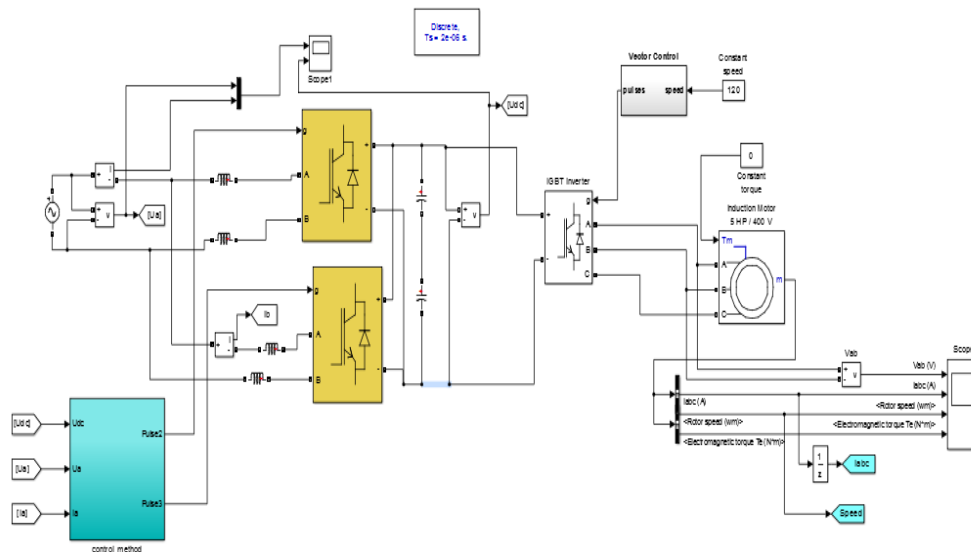

Figure 7: MATLAB model of two rectifier system

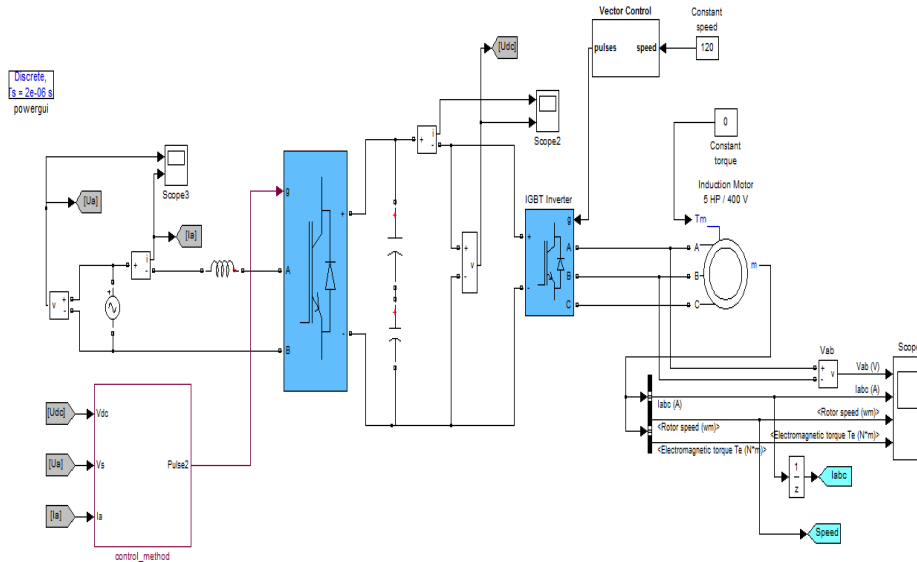

Figure 8: MATLAB model of one rectifier system (Conventional)

Both systems are developed in MATLAB software. The specification of the motor used in simulation is given in table 1. Figure 7 shows the complete developed model of two rectifier system and figure 8 shows the developed model of single rectifier system in MATLAB.

VI. Simulation Results Of One Rectifier System (Conventional)

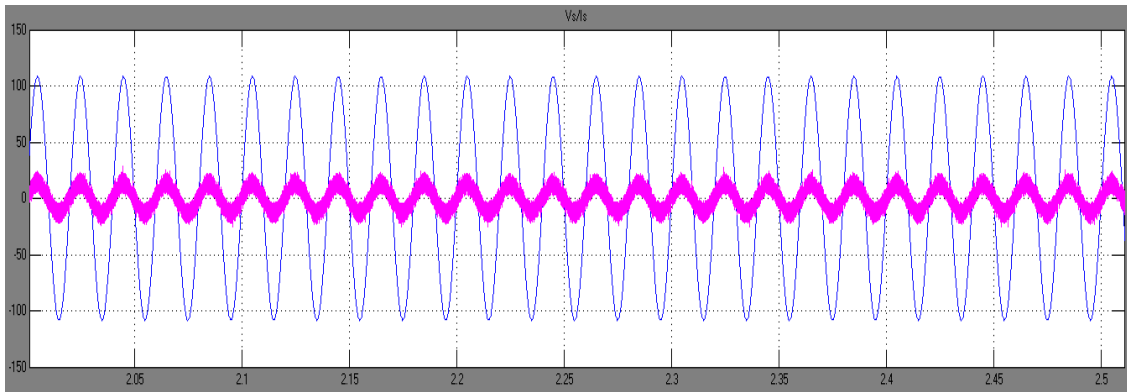

Figure 9.1: Input voltage and current

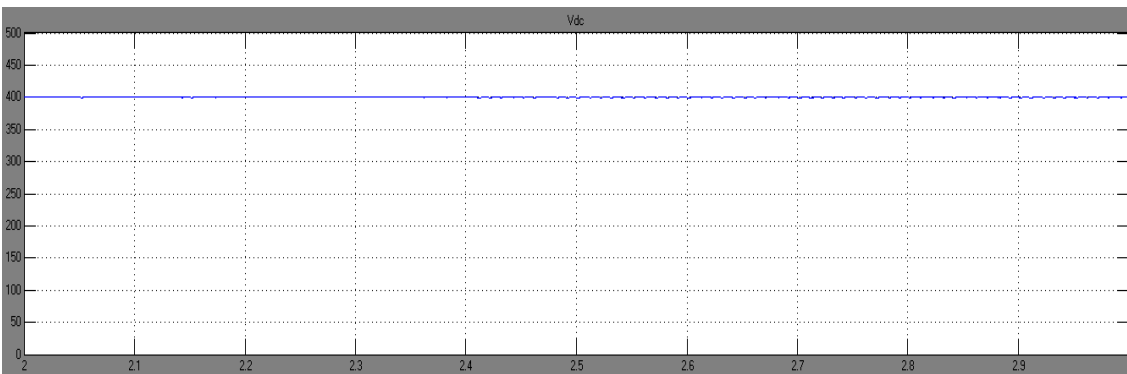

Figure 9.2: Dc link voltage

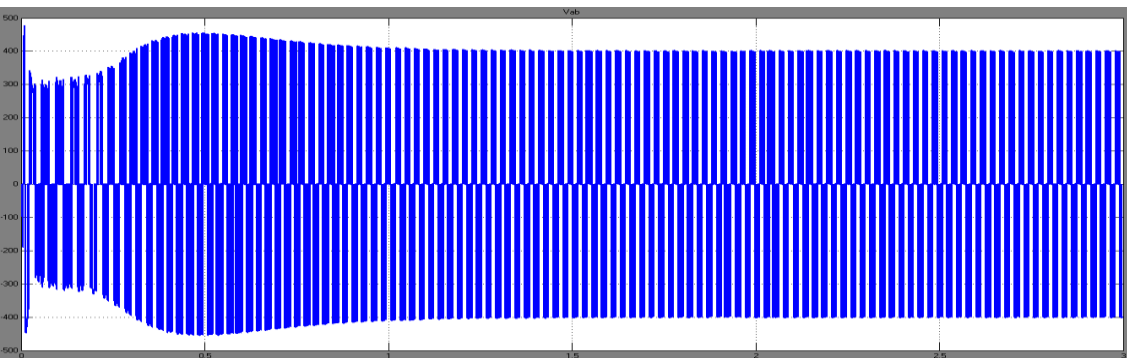

Figure 9.3: Phase voltage V_{a-b}

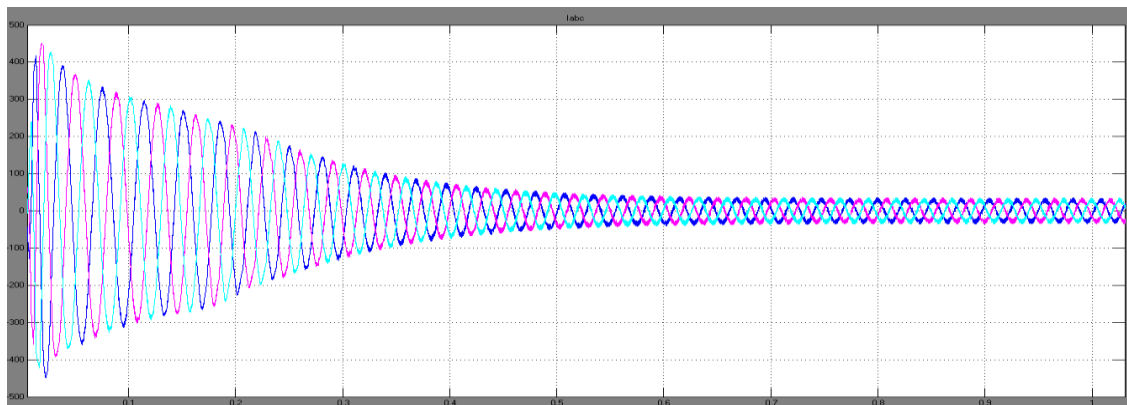

Figure 9.4: Three phase current

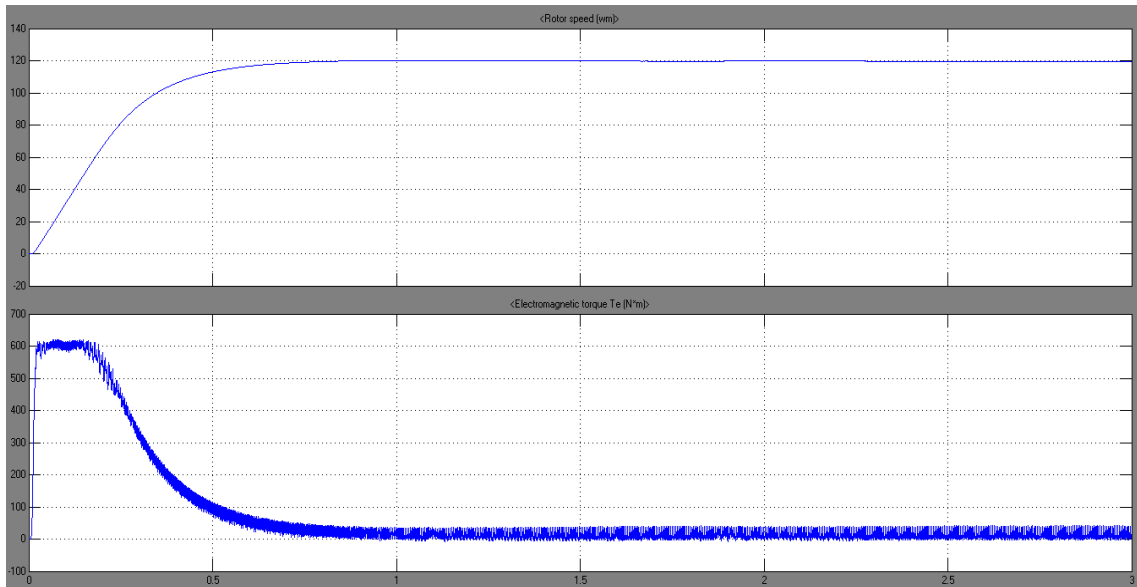

Figure 9.5: Speed and Electromagnetic torque T_e (Free acceleration $T_g = 0$)
 Figure 9 Simulation result of one rectifier system

Figure 9 shows the simulation results of one rectifier system. Where figure 9.1 shows input voltage and current of supply. Figure 9.2 shows the dc link voltage whereas figure 9.3 phase voltage between phase a and b of the inverter output. The three phase current motor current is shown in figure 9.4. Speed and electromagnetic torque of motor for free acceleration is given in figure 9.5 similarly the simulation results of two rectifier system are given figure 10.

VII. Simulation Results Of Two Rectifier System

Figure 10. Simulation result of two rectifier system

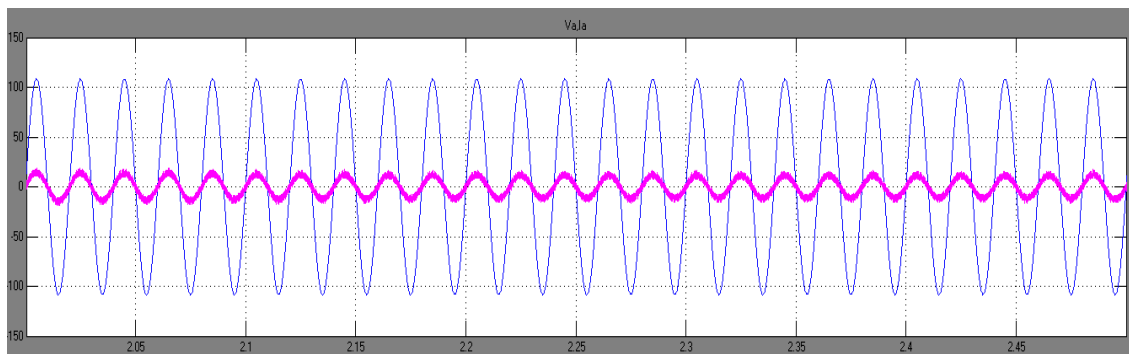

Figure 10.1: Input voltage and current

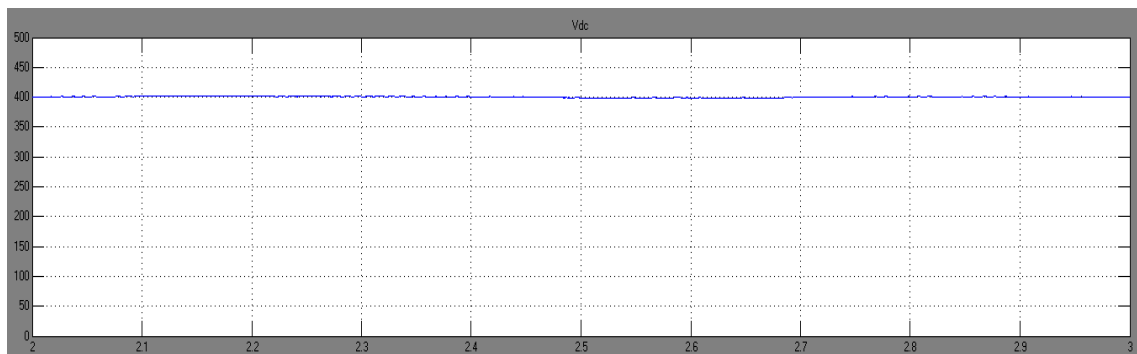

Figure 10.2: Dc link voltage

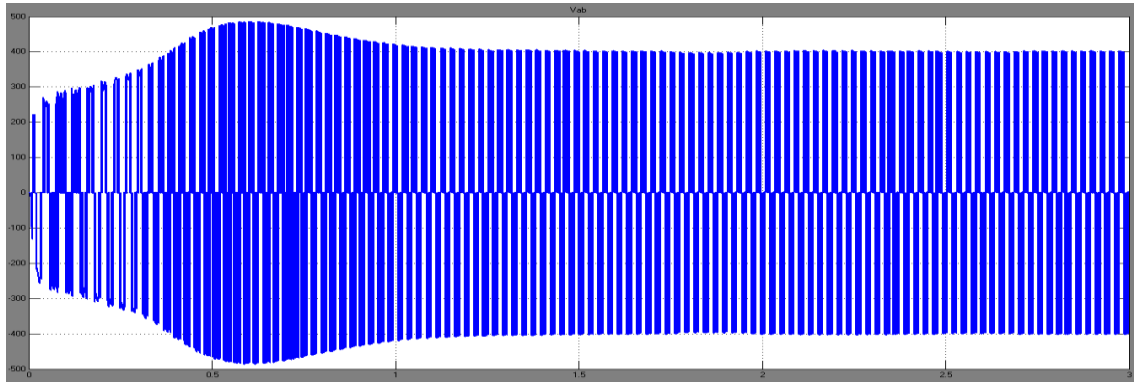

Figure 10.3: Phase voltage V_{a-b}

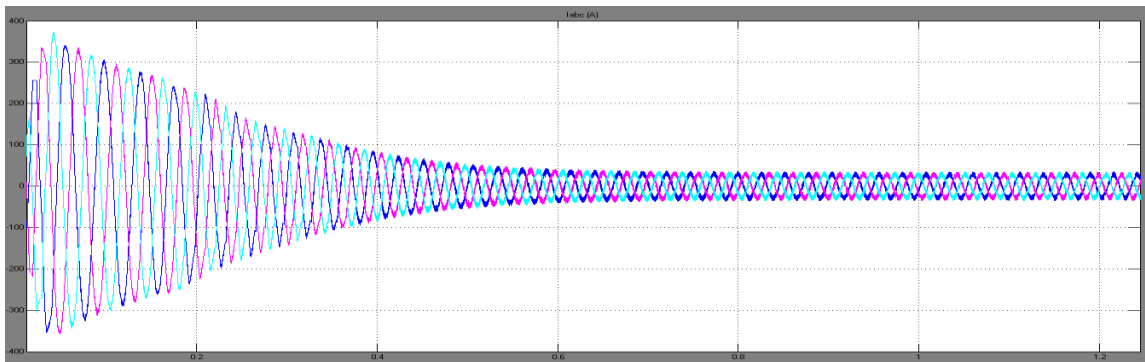

Figure 10.4: Three phase current

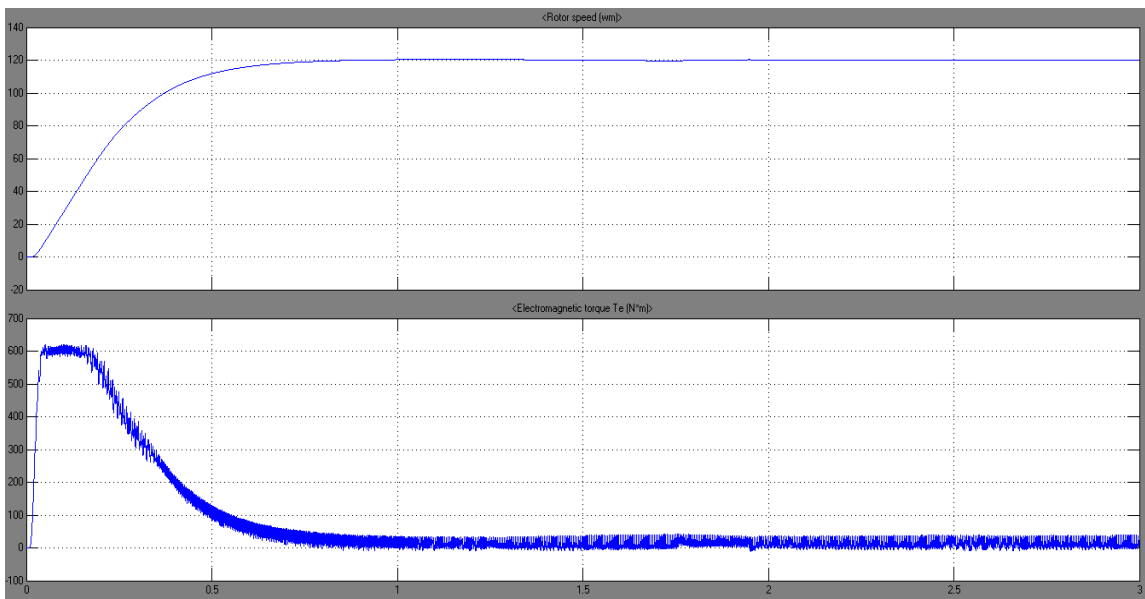

Figure 10.5: Speed and Electromagnetic torque T_e (Free acceleration $T_e = 0$)

Figure 10 shows the simulation results of two rectifier system. Where figure 10.1 shows input voltage and current of supply. Figure 10.2 shows the dc link voltage whereas figure 10.3 phase voltage between a-b phase of the inverter output. The three phase current motor current is shown in figure 10.4. Speed and electromagnetic torque of motor for free acceleration is given in figure 10.5

VIII. Total Harmonic Distortion (THD) Analysis Of Input Current

Simulation is run for 150 cycles and FFT analysis of input current is done. Following table shows the THD readings for different number of cycles. THD are measured from initial time i.e from zero

CONFIGURATION	PERCENTAGE THD IN INPUT SUPPLY CURRENT	NUMBER OF CYCLES	PERCENTAGE REDUCTION IN TWO RECTIFIER SYSTEM
One rectifier system	7.52	150	2.41
Two rectifier system	5.11		
One rectifier system	18.82	100	0.75
Two rectifier system	18.07		
One rectifier system	18.81	50	1.15
Two rectifier system	17.66		

Table 3 Comparison of two systems

Sr. No	Parameters	One rectifier (Conventional system)	Two rectifier (Parallel System)
1	THD	More	less
2	No of component	10	14
3	Cost	More	less
4	Input current shaping	Yes	Yes
5	Boost inductor	1	4

IX. Conclusion

MATLAB simulation of three phase induction motor drive supplied from single phase supply with parallel connected rectifier and with one rectifier is developed in this paper. The parallel rectifier system helps to reduce the rectifier switch Currents, and the total harmonic distortion (THD) of the grid current with same switching frequency. In addition, the losses of the proposed system may be lower than that of the conventional counterpart. The system control strategy is fully developed and all the simulation results are presented. Because of the decrease in the rectifier switch current, the rating of switches decreases in rectifier circuit of proposed configuration which may helps in reducing cost of the system.

REFERENCES

- [1] P. Enjeti and A.Rahman, Jul./Aug. 1993. "A new single phase to three phase converter with active input current shaping for low cost AC motor drives," IEEE Trans. Ind. Appl., vol. 29, No.2, pp. 806–813.
- [2] Dong-Choon L and Young-Sin K, April 2007, "Control of Single-Phase-to-Three-Phase AC/DC/AC PWM Converters for Induction Motor Drives," IEEE Trans. On Ind. Electronics, vol. 54, No. 2.
- [3] Euzeli C D S, Cursino B J, Edison R C d S, and Nady R, MAY 2012, "Single-Phase to Three-Phase Power Converters: State of the Art" IEEE Trans. On Power Electronics, VOL.27, NO. 5.
- [4] Euzeli Cipriano dos Santos, Cursino Brandˆao Jacobina, MAY 2012, "Single-Phase to Three-Phase Power Converters: State of the Art" IEEE TRANSACTIONS ON POWER ELECTRONICS, VOL. 27, NO. 5.
- [5] Limits for Harmonic Current Emissions (Equipment Input Current up to and Including 16 A Per Phase), IEC 61000-3-2 International Standard, 2000.
- [6] B. Singh, B. N. Singh, A. Chandra, K. Al-Hadad, A. Pandey, and D. Kothari, "A review of single-phase improved power quality AC-DC converters," IEEE Trans. Ind. Electron., vol. 50, no. 5, pp. 962–981, Oct. 2003
- [7] José R. R, Juan W. D, José R. E, Jorge P and Pablo L, February 2005, "PWM Regenerative Rectifiers: State of the Art," IEEE Trans. On Ind. Electronics, vol. 52, no.1.
- [8] Cursino B J, Euzeli C d S, Nady R, and Edgard L L F, MAY 2010, "Single-Phase to Three-Phase Drive System Using Two Parallel Single-Phase Rectifiers" IEEE Trans. On Power Electronics, VOL. 25, NO. 5.
- [9] Mariusz M, Marian P. Kazmierkowski, and Andrzej M. T, November 2003, "A Comparative Study of Control Techniques for PWM Rectifiers in AC Adjustable Speed Drives," IEEE Trans. Power Electron., vol. 18, no.6.
- [10] Krause, P. C. Analysis of Electric Machinery. New York: McGraw-Hill, 1994.