

Industrial Microcontroller Based Neural Network Controlled Autonomous Vehicle

D. Praveen Kumar¹, G. Sai Sudarsan², P. Dinesh³, K Anil⁴, Y. Govardhan⁵
¹²³⁴⁵(Department of Electronics and control Engineering, Sree Vidyanikethan Engineering College, India)

Abstract: This paper essentially deals with the design and implementation of a low cost autonomous vehicle which is controlled by neural network and is based on micro controller. The autonomous vehicle is equipped with a ultrasonic sensor for hurdle distance measurement, a GPS receiver for goal position information, a GSM modem for changing destination place on run time and a nonvolatile RAM for storing waypoint data; all these are interfaced to a Renesas RL78 microcontroller. This microcontroller processes the information acquired from the sensors and generates robot motion commands accordingly through neural network. The neural network which is running inside the microcontroller is a multilayer feed-forward network with back-propagation training algorithm which is trained offline with tangent-sigmoid as activation function for neurons and is implemented in real time with piecewise linear approximation of tangent-sigmoid function. This autonomous vehicle is tested to navigate inside college campus and has achieved better results.

Keywords: autonomous vehicle; ultrasonic sensors ;compass; GPS receiver ;GSM modem ;nonvolatile RAM ;tangent-sigmoid function approximation ;neural network ;microcontroller implementation.

I. INTRODUCTION

Autonomous robots are robots that can perform desired tasks in unstructured environments without continuous human guidance. Many kinds of robots have some degree of autonomy. Different robots can be autonomous in different ways. A high degree of autonomy is particularly desirable in fields such as space exploration, cleaning floors, mowing lawns, and waste water treatment. Navigation is the ability of a mobile robot to reach the target safely without extended human assistance. So the main issues that are needed to be addressed in mobile robot navigation are obstacle avoidance and target acquisition.

Navigation comprises two tasks hurdle avoidance and goal reaching. Hurdle avoidance is achieved with the help of ultrasonic sensors and IR sensors. The data from these sensors is given to neural network running inside the primary microcontroller. To minimize the computational burden on the microcontroller, a neural network is implemented with piecewise linear approximation of tangent-sigmoid activation function for neurons. Goal reaching behavior involves the data from the ultrasonic sensors, IR sensors and GPS receiver which is processed by another microcontroller. The goal is a set of latitude and longitude location to which the robot need to navigate. The primary microcontroller fetches the desired data and generates motion commands for robot. A GSM modem which is interfaced to the main controller is used for selecting start and goal stations for robot inside the university campus.

II. PROTOTYPE

The prototype is implemented on a two wheeled mobile robot which is a made on chassis. The two microcontrollers, primary and secondary along with ultrasonic sensors, IR sensors, GPS sensor and GSM modem will be on the chassis while the chassis will be placed on the wheels that are driven by DC stepper motors along with a pivot wheel. The whole setup is driven by 18v DC power supply either from a battery or AC/DC adapter. The Quectel M10 GSM modem will be a used to communicate with the robot like sending the GPS coordinates or receiving the GPS coordinates of the robot. The GPS sensor which will work based on satellite navigation system will be continuously sensing the location which can be known through the commands. The Design of the prototype starts with mechanical design after which the circuit design is done. The mechanical design is done in such a way that all sensors are placed such that they cover the maximum area, which makes it easy to detect the sensors. All the other components are placed in appropriate places. Then circuit design was carried out in two phases, sensor part design and the control board design.

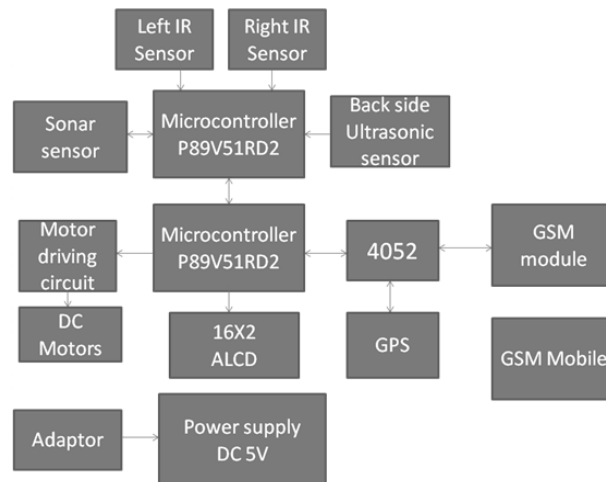

Figure 1. Block diagram

III. NAVIGATION SYSTEM

Navigation problem is decomposed into obstacle avoidance and goal reaching problems.

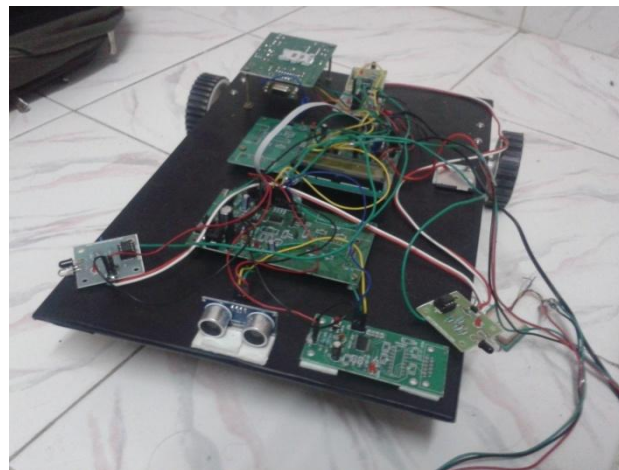

Figure 2. Experimental Prototype

A. Obstacle Avoidance

When a mobile robot is traveling towards its final target, it might face a variety of obstacles in its way. A neural network controller is designed to cope up with these situations.

Neural network design: The neural network used is multi layer feed-forward network with back propagation learning algorithm and is designed using MATLAB® programming environment. The employed configuration contains 3 neurons in the input layer, 6 in the hidden layer and 4 in the output layer as shown in Fig. 4. The numbers of neurons in hidden layer are selected on trial and error basis. Three inputs to the neural network are distance information from 4 sensors. Centre and back sensors are combined to form one input while other two inputs are from left and right sensors. The outputs from the neural network are direct commands for motors. The activation function used for hidden layer is tangent-sigmoid function while pure linear function is employed in output layer.

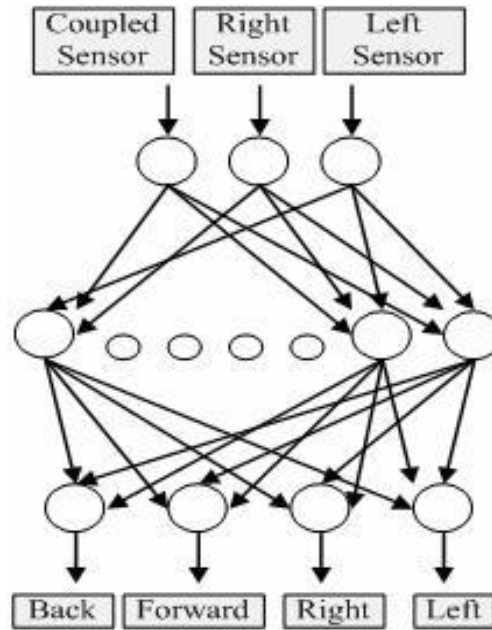

Figure 3. Neural Network Model

The output of a neuron can be expressed by the equation:

$$Y_i = T(\sum_j (X_j * W_{ij})) \quad (1)$$

where T is the transfer function which is made user selectable, either sigmoid, threshold or custom made. This equation will be applied to calculate the output of hidden and output layer. For hidden layer, (1) will be

$$H_j = \text{tansig}(\sum_j (X_j * W_{ij})), j = 1 \text{ to } 6, i = 1 \text{ to } 3 \quad (2)$$

Similarly for output layer, (1) will be:

$$O_j = \text{purline}(\sum_j (X_j * W_{ij})), j = 1 \text{ to } 4, i = 1 \text{ to } 6 \quad (3)$$

Experimental data is divided into two sets: training data set and validation data set. During training, for each sample value, error is calculated between the desired output 'H' and network calculated output 'Y'. The following figure is the schematic of the neural network.

B. Goal Reaching:

$$E = H - Y \quad (4)$$

The error is minimized by using backpropagation training algorithm. The algorithm minimizes the error by updating the weights and biases of the network. For a tangent-sigmoid function, new weights are calculated according to the relation:

$$W_{new} = W_{old} + \eta(1 - \alpha) \Delta W + \alpha \Delta W_{old} \quad (5)$$

where ΔW is the weight correction factor and α is the momentum factor used for convergence of network output to desired behavior by speeding up the iterative process. After performance goal is met in training phase, the network is tested with validation data set. This data set is used to avoid over-fitting the network to the training data. The training error graph showing the performance of network is shown in Fig. 5. 3) Neural network implementation: After Offline training in MATLAB®, the neural network is implemented using Renesas Microcontroller. Keeping in view the low memory and processing power of the microcontroller, tangent sigmoid function is converted in piecewise linear function for implementation in microcontroller and the converged weights are converted into integer form. The approximated function is described in the following equations.

The following equations are coded in the microcontroller.

$$\begin{aligned} f(x) &= 0.8x \text{ if } 0 \leq x < 1 \\ f(x) &= .2x + 0.6 \text{ if } 1 \leq x < 1.8 \\ f(x) &= 0.05x + 0.87 \text{ if } 1.8 \leq x < 2.5 + 1 \text{ if } x \geq 2.5 \end{aligned} \quad (6)$$

During navigation, if the obstacle avoidance system detects an obstacle, the control commands for avoiding the obstacle will override the normal commands provided by goal reaching system. In this case, vehicle will travel more distance than desired. The extra distance traveled by vehicle after avoiding the obstacle is recorded. Then knowing the current and destination (active waypoint) vehicle orientation, a new path is

generated along with new distance to be traveled to reach that waypoint. When the vehicle reaches within 5 meter of current waypoint, position value is read with the help of GPS receiver and new waypoint is loaded.

IV. RESULTS

Experiments performed with the prototype and the neural network simulations done on Matlab has proven better results for navigation in university campus the following are the results of the neural network toolbar are as follows.

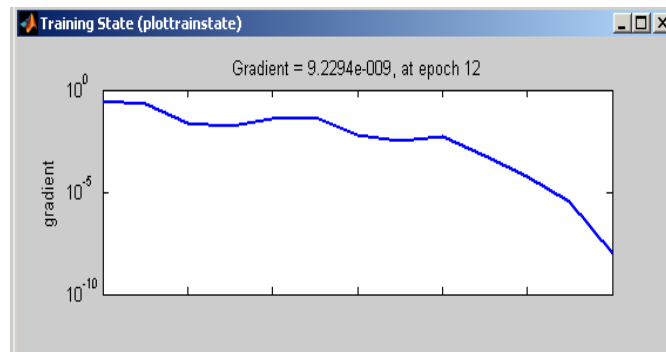

Figure 4. Training state

V. CONCLUSIONS

In this paper, design of a low cost autonomous vehicle based on neural network is presented for navigation inside the university campus. Equipped with various sensors, the vehicle has the capability of navigating in complex environments avoiding the obstacles in its way and reaching the target. The complexity of the system is reduced by making it modular i.e., more modules can easily be added to system by setting their priority level in the main controller.

REFERENCES

Journal Papers:

- [1] Nielsen L., "Automated Guidance of Vehicles using Vision and Projective Invariant Marking", *Automatica* 24:2, pp. 135-148, 1988.
- [2] Schraft R.D., "Mechatronics and Robotics for Service Applications", *IEEE Robotics & Automation Magazine*, pp. 31-37, December 1994.
- [3] Harris G., "Robotics Decontamination Keeps Operators Clear of Danger", *Industrial Robot*, 20:3, pp. 30-33, 1993.
- [4] Weisbin C.R., D.Lavery, " NASA Rover and Telerobotics Technology Program " , *IEEE Robotic & Automation Magazine*, pp. 14-20, December 1994.
- [5] Evans J., Krishnamurthy B., "Handling Real World Motion Planning A Hospital Transport Robot", *IEEE Control Systems*, pp.15-19, February 1992.
- [6] Orwig T, "Cybermotion's Roving Robots", *Industrial Robot*, 20:3, pp. 27-29, 1993.
- [7] Khaldoun K. Tahboub, Munaf S. N. Al-Din, "A Neuro-Fuzzy reasoning system for mobile robot navigation," *Jordan Journal of Mechanical and Industrial Engineering*, vol. 3 (1), pp. 77-88, March 2009.
- [8] Jonathan Milton Turner, obstacle avoidance and path traversal using interactive machine learning , M.S Thesis, Brigham Young University, August 2007.
- [9] Alexander Schepelmann, Henry H. Snow, Bradley E. Hughes, Frank L. Merat, Roger D. Quinn, "Vision-Based Obstacle Detection and Avoidance for the CWRU Cutter Autonomous Lawnmower" M Ozaki, Y. Adachi, Y. Iwahori, and N. Ishii, Application of fuzzy theory to writer recognition of Chinese characters, *International Journal of Modelling and Simulation*, 18(2), 1998, 112-116.