

Selection of Effective Control Technique in Analysis of Pulsed Power Loads

D. Rajalakshmi¹, L. Jeniferamla²,

¹(Department of Electrical Electronics Engineering)

²(Department of Electrical and Electronics Engineering)

ABSTRACT

This paper considers the effect of Pulsed Power Loads (PPLs) on micro-grid power systems, such as those on warships, pulsed weapons and recovery systems. A design metric to describe the disturbance of PPLs on power systems is presented. A control strategy utilizes the design metric to reduce the impact of PPL. This strategy is based on identifying the optimal charging profile. Using simulation, it is shown the proposed strategy is highly effective in reducing the adverse impact of pulsed-power loads by reducing the impulse response of capacitor current. This paper outlines an approach to analyze the effects of such loads upon the electric power grid using the proposed technique trapezoidal based control (TBC) and a charging profile is developed for the existing analysis technique limit based control (LBC). Both the control techniques are compared to find the effective approach in reducing the impact of pulsed power loads.

Keywords: Marine vehicles, military aircraft, power quality, energy storage, pulsed power systems.

I. INTRODUCTION

Pulsed Power Loads (PPLs) are of significant interest in navy applications such as future warship development. It is often the case in such loads that the energy storage element is charged over a finite interval of time, and then rapidly discharged [1]. The charging of the energy storage device is an intermittent load which disturbs the power system. Examples of this class of system include high power radars, electromagnetic launch and recovery systems, and pulsed weapons such as rail guns [2], [3]. The power requirements of the charge cycle on such loads can extend into tens of megawatt range with a charge interval on the order of seconds to minutes [4]. The discharge duration is normally much shorter, and is often essentially instantaneous compared to the charge interval wherein energy is accumulated from the power system. These pulses can cause significant disturbance to the rest of the power system [2], [5]. The goal of this work is to minimize the system impact of these Pulsed Power Loads (PPLs) by designing the capacitor current. This work begins with the development of a metric to describe the disturbance caused by a PPL [1]. This metric is then solved to obtain an optimal power trajectory. A state feedback based approach to achieving this desired trajectory is then set forth. The PPL in this system uses capacitor energy storage and is designed to emulate a rail gun application. Through simulation studies, the performance of two types of control strategies such as limit based control (LBC) and trapezoidal based control (TBC) is compared to obtain an effective approach. It is shown that the performance of the proposed control (TBC) is significantly superior to the existing control (LBC) in terms of reducing the impulse response of capacitor current. One method to reduce the impact of pulsed loads is through the introduction of supplementary energy storage devices, such as flywheels [2],[5]. While effective, such an approach clearly adds mass and expense to the system.

Another method to reduce the disruption caused by PPLs is through load coordination. In such an approach, the base load is shed in order to accommodate the pulsed load, so that the total system load remains constant. Such an approach is considered in [5], [7], and [8]. As an alternative to LBC, auxiliary energy storage, and coordination strategies, a trapezoidal-based control (TBC) was set forth. This control was based on using a trapezoidal load profile. The parameters governing the shape of the trapezoid were selected so as to minimize the disruption caused by the pulsed load. However, this work assumed *a priori* that the trapezoidal power profile was the optimal shape. Here using simulation it is proved that the proposed scheme is effective in reducing the impact of PPL by eliminating the impulse response. And a charging profile is developed for the existing control to identify the optimal trajectory.

II. CIRCUIT DESCRIPTION

The circuit topology of the PPL is depicted in Fig. 1. The circuit includes an input filter and a buck converter. The input filter is designed to reduce the high frequency current ripple associated with the buck converter from entering the power distribution system. The buck converter regulates the current i_l so as to charge the energy storage capacitor C_{es} according to the desired profile.

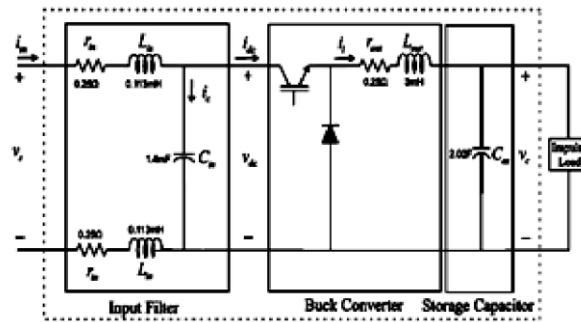

Fig.1.circuit diagram

The pulsed load is that part of the PPL which discharges the capacitor. The storage capacitor used here plays an important role in PPL.the aim is to charge and discharge the capacitor as soon as possible subjected to current and power limits. This paper is entirely concerned with the generation of capacitor current and thereby reducing the impulse response obtained during charging and discharging of capacitor. In the circuit, the energy storage capacitor is emulated so that the energy storage does not need to be physically achieved, and to make it easier to achieve the appearance of a rapid discharge.

III. DESIGN METRIC AND NORMALIZATIONS

The first step in minimizing the system impact of the PPL is to define a metric to describe the disturbance caused by the PPL. A natural choice for such a metric would be related to the bus voltage during and after the PPL charge cycle. However, the problem with such an approach is that the evaluation of the metric becomes not only a function of the PPL, but also of the system, and thereby every component and control parameter therein. Thus, in this work, an alternate metric is proposed, one which only involves the PPL.The disturbance of a PPL on a system is related to its time power profile. This profile is denoted as $P_p(t)$ and is referred to as the power trajectory herein. The power trajectory must satisfy several constraints. First, the power trajectory must be such that the desired energy is obtained. Thus

$$\int_0^{T_p} P_p(t)dt = \Delta E_p^* \quad (1)$$

where ΔE_p^* is the incremental additional energy to be stored in the energy storage element during the charge cycle and T_p is the period of the charge cycle. Note that prior to the charge cycle, the amount of energy stored is not necessarily zero. This initial energy storage is denoted E_{po} .Second, it is desirable that the power trajectory is a continuous function of time. Thus it is required that

$$P_p(t) \in C_0 \quad (2)$$

where C_0 is the set of continuous functions. This facilitates implementation in the presence of parasitics, and also limits the bandwidth of the PPL disturbance on the system. By definition, a pulsed load is an intermittent transient load. Requirement (2) is thus coupled with the requirement that

$$P_p(0) = P_p(T_p) = 0 \quad (3)$$

Finally, it is desired that the system disturbance caused by the trajectory is minimized. In order to quantify this last point, observe that if the PPL were not pulsed, i.e. were a constant, then there would be no disturbance at all. Hence, one philosophy for a disturbance metric is to define the metric in terms of the time rate of change of the power trajectory. To this end, the disturbance metric

$$dp = \sqrt{\frac{1}{T_p} \int_0^{T_p} \left(\frac{dP_p(t)}{dt} \right)^2 dt} \quad (4)$$

is proposed. In (4) dP_p/dt , is the time rate of change of power into the PPL. Before proceeding to explore the solution to this problem, it is convenient to normalize quantities of interest so that the results are readily scaled. To this end, the base energy will

$$E_p^\wedge = \frac{(E_p - E_{po})}{\Delta E_p^*} \quad (5)$$

Next, time is normalized to the charge cycle period T_p . Thus, normalized time is defined

$$t^{\wedge} = \frac{t}{T_p} \tag{6}$$

Finally, the base power is defined as

$$P_{p,b} = \frac{E_p^*}{T_p} \tag{7}$$

whereupon normalized power may be expressed

$$P_p^{\wedge}(t) = \frac{P_p(t)}{P_{p,b}} \tag{8}$$

In terms of normalized quantities, (1)-(4) become

$$\int_0^1 P_p^{\wedge}(t^{\wedge}) dt^{\wedge} = 1 \tag{9}$$

$$P_p^{\wedge}(t^{\wedge}) \in C_o \tag{10}$$

$$P_p^{\wedge}(0) = P_p^{\wedge}(1) = 0 \tag{11}$$

$$dp^{\wedge} = \frac{d_p T_p}{P_{p,b}} = \sqrt{\int_0^1 \left(\frac{dP_p^{\wedge}(t)}{dt^{\wedge}} \right)^2 dt^{\wedge}} \tag{12}$$

respectively. The metric function and constraints can be solved to find the optimal power trajectory. The next section of this paper will show this by applying the metric to a desired power profile.

IV. OPTIMAL TRAPEZOIDAL TRAJECTORY

In this section, the metric defined in the previous section will be used to find the optimal power trajectory subject to a trapezoidal power profile. This case is of interest because of its straightforward implementation. The trapezoidal power trajectory is depicted in Fig.2 where t_r^{\wedge} is the normalized rise time, t_f^{\wedge} is the normalized fall time, and P_{pk}^{\wedge} is the normalized peak power.

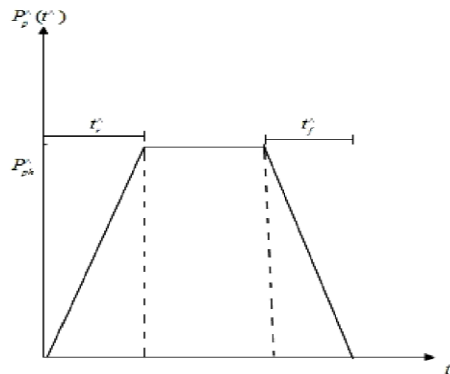

Fig.2.trapezoidal power trajectory

Finding the optimal trajectory involves finding the parameters of the trapezoid which minimize the performance metric. As a prologue to this optimization, it is convenient to define the objective

$$g_p^{\wedge} = d_p^{\wedge 2} \tag{13}$$

Therefore, (12) becomes

$$g_p^{\wedge} = \int_0^1 \left(\frac{dP_p^{\wedge}(t^{\wedge})}{dt} \right)^2 dt \tag{14}$$

Minimization of \hat{g}_p is exactly equivalent to minimization of \hat{d}_p but results in a simpler development. Mathematically, the trapezoidal trajectory may be expressed

$$P_p^\wedge(t^\wedge) = \left\{ \begin{array}{l} \frac{P_{pk}^\wedge}{t_r^\wedge} t^\wedge \quad (t^\wedge \leq t_r^\wedge) \\ P_{pk}^\wedge (t_r^\wedge < t^\wedge \leq 1 - t_f^\wedge) \\ -\frac{P_{pk}^\wedge}{t_f^\wedge} t^\wedge + \frac{P_{pk}^\wedge}{t_f^\wedge} (1 - t_f^\wedge) \quad (1 - t_f^\wedge < t^\wedge \leq 1) \end{array} \right\} \quad (15)$$

Substitution of (15) into (9) yields the constraint

$$P_{pk}^\wedge \left(1 - \frac{t_r^\wedge}{2} - \frac{t_f^\wedge}{2} \right) = 1 \quad (16)$$

The time derivative of the trapezoidal profile is given by

$$\frac{dP_p^\wedge}{dt^\wedge} = \left\{ \begin{array}{l} \frac{P_{pk}^\wedge}{t_r^\wedge} (t^\wedge \leq t_r^\wedge) \\ 0 (t_r^\wedge < t^\wedge \leq 1 - t_f^\wedge) \\ -\frac{P_{pk}^\wedge}{t_f^\wedge} (1 - t_f^\wedge < t^\wedge \leq 1) \end{array} \right\} \quad (17)$$

Substitution of (17) into (14) yields

$$\hat{g}_p = P_{pk}^{\wedge 2} \left(\frac{1}{t_r^\wedge} - \frac{1}{t_f^\wedge} \right) \quad (18)$$

and combining the constraint (16) and (18) manipulating yields

$$\hat{g}_p = \frac{1}{\left(1 - \frac{t_s^\wedge}{2}\right)^2} \frac{4t_s^\wedge}{(t_s^{\wedge 2} - t_\Delta^{\wedge 2})} \quad (19)$$

where

$$t_s^\wedge = t_r^\wedge + t_f^\wedge \quad (20)$$

Equations (15) can be viewed as a parametric relationship between P_p^\wedge and E_p^\wedge . Eliminating from the parametric relationship yields

$$P_p^\wedge = f_p(E_p^\wedge) = \left\{ \begin{array}{l} \frac{3}{2} \sqrt{4E_p^\wedge} \dots \dots \dots (E_p^\wedge \leq \frac{1}{4}) \\ \frac{3}{2} \dots \dots \dots (\frac{1}{4} < E_p^\wedge \leq \frac{3}{4}) \\ \frac{3}{2} \sqrt{-4(E_p^\wedge - 1)} \dots \frac{3}{4} < E_p^\wedge \leq 1 \end{array} \right\} \quad (21)$$

Suggested values for E_{LT}^\wedge and E_{HT}^\wedge range from 0.001-0.05 and 0.95-0.999, respectively. At this point, a new control method derived from the metric to minimize system impact of the PPL has been presented.

V. CONTROL DESCRIPTION

The control description of pulsed power loads can be described by charge discharge control and capacitor current command synthesizer. The charge discharge layer formulates charge and discharge commands and the current synthesizer utilize the desired charge profile and generate the capacitor current accordingly.

5.1. Charge discharge control

The charge/discharge control is presented in [6] shows a modified control used herein. The difference between the control in [6] and this control is the addition of the one-shot or control variable. The inputs to the control are a command to enable the charging of the capacitor, a command to discharge, the filtered voltage across the energy storage capacitor, the desired capacitor voltage for firing, and the current measured voltage of the energy storage capacitor. The outputs of this control are the actual charging status, (high to charge) and the actual discharge status, (high to discharge). Provided that a discharge sequence is not underway and that the capacitor voltage is below the voltage sufficient for firing, setting high will cause the charge status to go high, whereupon the capacitor will be charged. The oneshot flag is high if a single shot is desired and low if it is desired to repeatedly go through the firing sequence as rapidly as possible. If is reset after a charge period, the PPL will repeat the charge and discharge sequence. If the energy storage capacitor voltage is above the threshold when the oneshot flag is enabled, and if is high, a discharge sequence is enabled. During the discharge sequence, the net effect of the control is that the charge status will be disabled for a period of time defined by and the discharge status will be enabled for the last seconds of this cycle. This provides a short period of time when both the charge and discharge cycles are disabled.

5.2. Capacitor current synthesizer

This layer of the control formulates the capacitor current command. The proposed control scheme trapezoidal based control is set forth. Therefore the two control schemes will be considered and compared. The first control scheme charges the capacitor as rapidly as possible subject to current and power limits without including a storage time, the waveform is parabolic. The second control scheme generates the capacitor current which makes use of storage time. The shape of the waveform is trapezoidal. This scheme was suggested in [9]. The second control scheme is the one proposed herein.

5.2.1 Current and Power Limit Based Current Command Synthesizer (LBC)

The current and power limit based current command synthesizer control, is shown in Fig. 3.

The basic philosophy of the control is to charge the capacitor as rapidly as possible subject to a peak capacitor current limit $i_{c,max}$ and a peak power limit $P_{c,max}$. Inputs to this control are the target final capacitor voltage, v_{c1}^* , the measured capacitor voltage, v_c , and the charge status, e_c . As can be seen, the measured capacitor voltage is first filtered by a low pass filter with time constant τ_{inf} and then subtracted from the command. The voltage error is then multiplied by a proportional gain K_{sf} and limited to a dynamic limit $i_{c,limit}$.

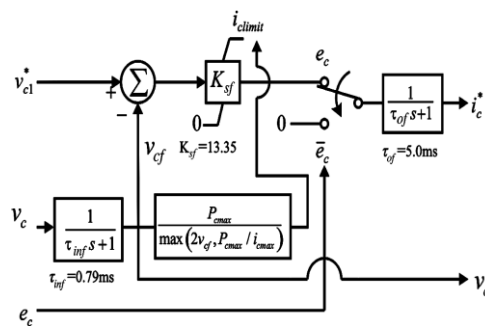

Fig.3.LBC current command synthesizer

Note that K_{sf} is selected to be large enough that the limit is almost always in effect until the point where V_{cf} becomes very close to v_{c1}^* ; after this point the capacitor voltage approaches the target voltage asymptotically. For this reason the target voltage v_{c1}^* is set slightly higher than the minimum voltage to fire, v_{c2}^* . The output of above control is capacitor current, i_c which is derived and then plotted using simulation. The simulation results are shown in fig.4.a,4.b,4.c the parameters such as capacitor current, i_c , load voltage, v_L , input current, i_c , are plotted. The simulation parameters for limit based control are listed in table I

TABLE 1
LBC SIMULATION PARAMETERS

| | | |
|-------------|----------|----------------------------------|
| V_{c1}^* | 410 V | Target capacitor firing voltage |
| V_{c2}^* | 405 V | Minimum capacitor firing voltage |
| $P_{c,max}$ | 13.52 kW | Capacitor power limit |
| $i_{c,max}$ | 40.52 A | Capacitor current limit |

LBC transient study results (simulation)

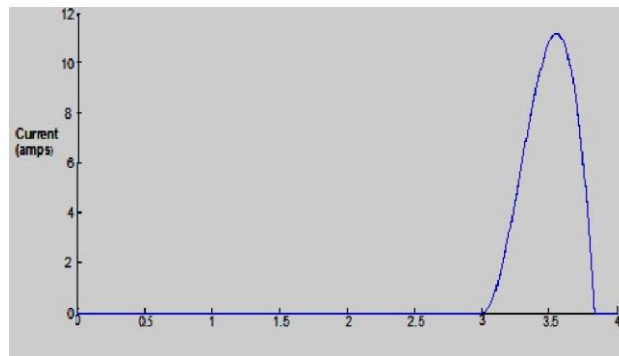

Fig.4.a.capacitor current, i_c .

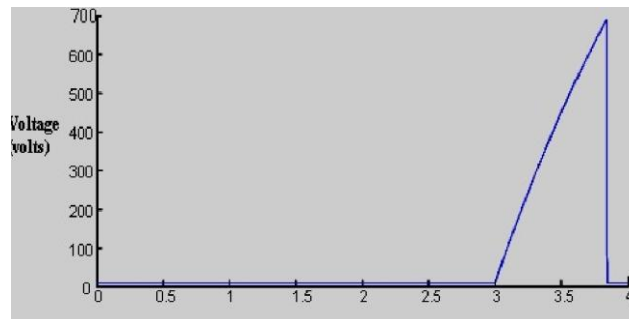

Fig.4.b.load voltage, V_L

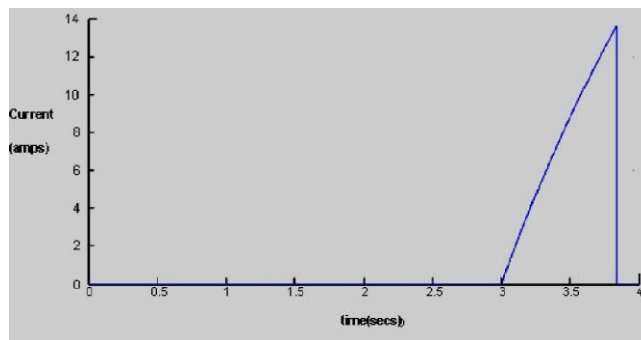

Fig.4.c.GTO current

5.2.2 Trapezoidal Capacitor Current Command Synthesizer (TBC)

The trapezoidal capacitor current command synthesizer control, or trapezoid based control (TBC), is based on (21). Note that this synthesizer results is a trapezoidal power profile; the capacitor current is a trapezoidal waveform. Like the LBC current command synthesizer, the output of this control is i_c^* . The control is shown in Fig. 5.

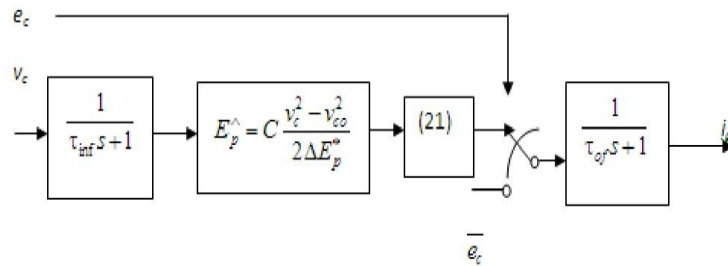

Fig.5.TBC current command synthesizer

The inputs to the control are the measured capacitor voltage v_c and the charge status, e_c . As can be seen, the measured capacitor voltage is filtered and fed into the normalized energy block, equation (5). This normalized energy is then fed into the current command synthesis block determines the preliminary current command. The output of the synthesizer is the capacitor current command, which is the output of the command synthesis block switched by the status of e_c . The control parameters for the TBC are listed in Table II. The control parameters are used in estimation of capacitor current, i_c , mathematically. It is proved that the mathematical calculation is almost equal to the simulation result. it is found that the mathematically calculated value of, i_c is 11.2A.and from simulation results it can be seen that the capacitor current value is 11A.

TABLE II
TBC SIMULATION PARAMETERS

| Parameter | Value | Description |
|-----------|---------|--------------------------------|
| T_{inf} | 0.79 ms | Time constant of input filter |
| T_{oj} | 5.0 ms | Time constant of output filter |
| K_c | 13.35 | Current forward gain |

TBC transient study results (simulation)

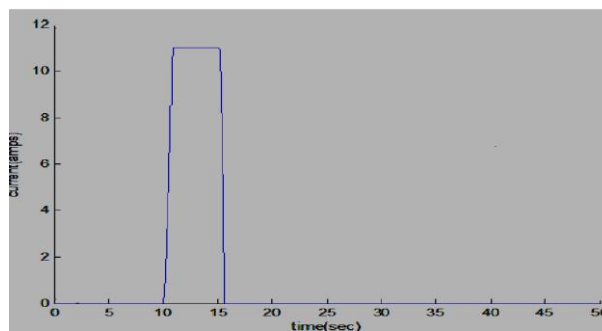

Fig.6.capacitor current

VI. SIMULATION RESULTS

In this section, simulation results for the two control methods are presented. A comparison of the disturbance to the system caused by both controls is presented. First the simulation result for limit based control with the capacitor current of 11A is generated as per the metric described above and the corresponding load voltage of 700V is obtained. Second, a simulation result for the trapezoidal control with a capacitor current of 11A is obtained. These results illustrate that the effect of pulsed power loads is reduced using trapezoidal based control. The impulse response of LBC is eliminated using TBC.

6.1. LBC Study

In this study, the system is initially in steady-state. At $t=3s$, a charging cycle is initiated. The goal is to charge the capacitor from 0 to 162 kJ in 3.8 s. Fig.6.a and 6.b depicts the results for the LBC. Variables depicted include the PPL capacitor current, i_c , the PPL load voltage, V_L , the dc current into the PPL, and the current in the GTO. These variables are all defined in Fig. 4.a, 4.b, 4.c.

As can be seen, the capacitor voltage ramps up nearly linearly in time, although there is a slight inflection at 3.5s, which corresponds to the control switching from the capacitor current limit to the power limit. The bus voltage is seen to gradually droop during the course of the charge cycle; however at the end of the charge cycle the bus voltage rises sharply and a pronounced peak occurs. The input current can be seen to rise nearly linearly until the control enters constant power mode, at which point the input current becomes constant. The peak value of input current is 14 A the current goes down as the power limit takes effect. The results of LBC are purely based on capacitor current derivation. It can be seen that the waveform is parabolic. The storage time is not included, the capacitor is charged in 0.5s and then rapidly discharged in 0.5s, and the load responds when the capacitor charges and discharges. Thus an optimal trajectory is formulated for the existing control.

6.2. TBC Study

Fig.6 depicts the performance of the TBC control. In this case, the capacitor current i_c is a trapezoidal waveform which eliminates the impulse response of the load. The aim of this control is to charge and discharge the capacitor as rapidly as possible with a short storage time. Thus the capacitor is charged in 0.5s and discharged in 0.5s with a storage time of 4s depending upon the application. The sudden dip in load voltage and current is avoided in this case. Due to the above result the sudden drop of voltage and current does not occur. The storage time is introduced in this strategy so that the load is not disturbed during the discharge of current. Thus this method is proved to be superior in eliminating the impulse response and thus it reduces the impact of pulsed power loads. It can be seen that, the capacitor current rises upto 11A as in LBC. The most significant difference between the two strategies in terms of waveform are the capacitor current, i_c . This result shows an advantage of the TBC over the LBC in its ability to function in large scenarios.

VII. CONCLUSION

A metric for describing the impact of PPLs on micro-grid power systems has been presented. This metric has been solved for an optimal power trajectory subject to a trapezoidal power profile in proposed scheme. The existing scheme is solved for a parabolic charging profile. The trapezoidal trajectory has been utilized in an application setting to validate its improvement to the power system. Thus the charging and discharging of an energy storage element will not disturb the power system. The results show that the developed power trajectory of trapezoidal control reduces the impact on the pulsed power loads by eliminating the impulse response as compared to the limit based control.

REFERENCES

- [1] J. Crider and S. D. Sudhoff, "Reducing impact of pulse power loads on microgrid power systems," *IEEE Trans. Smart Grid*, vol.1, no.3, dec 2010.
- [2] S. Kulkarni and S. Santoso, "Impact of pulse loads on electric ship power system: With and without flywheel energy storage systems," in *Proc. IEEE Electric Ship Technol. Symp. (ESTS 2009)*, pp. 568–573.
- [3] J. J. A. van der Burgt, P. van Gelder, and E. van Dijk, "Pulsed power requirements for future naval ships," in *Dig. Tech. Papers 12th IEEE Int. Pulsed Power Conf. 1999*, vol. 2, pp. 1357–1360.
- [4] H. Smolleck, S. J. Ranade, N. R. Prasad, and R. O. Velasco, "Effects of pulsed-power loads upon an electric power grid," *IEEE Trans. Power Del.*, vol. 6, no. 4, pp. 1305–1314, 1991.
- [5] L. N. Domaschk, A. Ouroua, R. Hebner, O. E. Bowlin, and W. B. Colson, "Coordination of large pulsed loads on future electric ships," presented at the 13th Electromagn. Launch Technol. Symp., Potsdam, Germany, May 2006.
- [6] M. Steurer, M. Andrus, J. Langston, L. Qi, S. Suryanarayanan, S. Woodruff, and P. F. Ribeiro, "Investigating the impact of pulsed power charging demands on shipboard power quality," in *Proc. IEEE Electric Ship Technol. Symp. (ESTS 2007)*, pp. 315–321.
- [7] B. Cassimere, C. Rodrijuez Valdez, S. Sudhoff, S. Pekarek, B. Kuhn D. Delisle, and E. Zivi, "System impact of pulsed power loads on a laboratory scale integrated fight through power (IFTP) system," presented at the Electric Ship Technol. Symp., Philadelphia, PA, July 25–27, 2005.
- [8] S. D. Sudhoff, B. T. Kuhn, E. Zivi, D. E. Delisle, and D. Clayton, "Impact of pulsed power loads on naval power and propulsion systems," presented at the 13th Int. Ship Control Syst. Symp., Orlando, FL, Apr. 7–9, 2003, Paper 236.

- [9] M. Bash, R. R. Chan, J. Crider, C. Harianto, J. Lian, J. Neely, S. Pekarek, S. D. Sudhoff, and N. Vaks, "Medium voltage DC testbed for ship power system research," presented at the IEEE Electric Ship Technol. Symp., Baltimore, MD, Apr. 20–22, 2009.
- [10] J. Crider and S. D. Sudhoff, "Reducing power system impact of pulsed power loads," presented at the Electric Machinery Technol. Symp., Philadelphia, PA, May 19–20, 2010
- [11] R. Hebner, "An electromagnetic gun power supply as a component of an electric ship power system," presented at the ASNE High Powered Weapons Syst. Elect. Ships Annapolis, MD, 2004. H. A. Toliyat, S. Talebi, P. McMullen, H. Co, and A. Filatov, "Advanced
- [12] High-speed flywheel energy storage systems for pulsed power applications," in *Proc. IEEE Elect. Ship Technol. Symp.*, 2005, pp. 379–386.
- [13] F. Paulo, B. K. Ribiero, M. L. Johnson, A. A. Crow, and L. Yilu, "Energy storage systems for advanced power applications," *Proceedings of the IEEE*, vol. 89, no. 12, pp. 1744-1756, Dec. 2001.
- [14] J. E. Van Ness, "Response of Large Power Systems to Cyclic Load Variations," *IEEE Trans. PAS*, Vol. PAS-85, pp. 723-727, July 1966.
- [15] K. R. Rao and L. Jenkins, "Studies on Power Systems that are Subjected to Cyclic Loads," *IEEE Trans. PAS*, Vol. 3, No. 1 (Feb.1988), pp. 31-37.
- [16] Electromagnetic Transients Program Rule Book, Electric Power Research Institute, Palo Alto, CA, 1986.

ACKNOWLEDGEMENT

D. Rajalakshmi received her bachelor's degree from Shanmuga college of Engineering, Tanjore, Tamilnadu, India in Electrical and Electronics Engineering during 2000. She received her Master's degree from Alagappa College of Engineering and Technology, Karaikudi, India during 2006. She is currently working as Assistant Professor at the department of Electrical and Electronics Engineering in Kumaraguru College of Technology, Coimbatore, India.

L. Jeniferamla received her bachelor's degree from Maharaja Institute of Technology, Coimbatore, Tamilnadu, India in Electrical and Electronics Engineering during 2010. She is currently doing her master's degree in Power Electronics and Drives at Kumaraguru College of Technology. Her interests include power electronics and electrical machines.